



Service Manual

Marine Generator Set

MDKDP (Spec A)

MDKDR (Spec A)

MDKDS (Spec A)

MDKDT (Spec A)

MDKDU (Spec A)

MDKDV (Spec A)

California

Proposition 65 Warning

Diesel engine exhaust and some of its constituents are known to the State of California to cause cancer, birth defects, and other reproductive harm.

Table of Contents

1. SAFETY PRECAUTIONS	1
1.1 Overview	1
1.2 Precaution Symbols	1
1.3 General Safety Precautions	2
1.4 Electrical Shocks and Arc Flashes Can Cause Severe Personal Injury or Death.....	4
1.5 Generator Voltage Is Deadly	5
1.6 Engine Exhaust Is Deadly.....	5
1.7 Diesel Fuel is Combustible	6
1.8 Battery Gas is Explosive.....	6
1.9 Moving Parts Can Cause Severe Personal Injury Or Death	6
1.10 Flammable Vapor Can Cause a Diesel Engine to Overspeed	6
1.11 Hazards of Carbon Monoxide	6
1.11.1 Carbon Monoxide Poisoning.....	7
1.11.2 Special Risks of CO on Boats.....	7
1.11.3 Protection From CO Poisoning	8
1.12 Substances Hazardous to Health	8
1.12.1 Antifreeze (Fleetguard - ES Compleat and EG Premix).....	8
1.12.2 Gas Oil	10
1.12.3 Lubricant Oil - Premium Blue E 15W40.....	12
1.13 Generator Set Warning Labels	13
2. INTRODUCTION.....	15
2.1 About This Manual	15
2.1.1 Warning - Generator Set Not Ignition Protected	15
2.2 Related Literature	16
2.3 Model Identification	17
2.3.1 Nameplate Location	17
2.4 Emissions Label.....	17
2.4.1 Typical Emissions Label Location.....	18
2.5 Noise.....	18
2.6 Electromagnetic Compatibility Compliance.....	18
2.7 Build Standards.....	18
3. MAINTENANCE	21
3.1 Periodic Maintenance	21
3.1.1 Periodic Maintenance Schedule	21
3.2 General Inspection.....	22
3.2.1 Service Point Locations	22
3.2.2 Battery Connections.....	23
3.2.3 Oil Level	23
3.2.4 Fuel System Leaks	24
3.2.5 Coolant Level	25

3.2.6 Raw Water System	25
3.2.7 Exhaust System	25
3.2.8 Mechanical System	26
3.3 Maintaining the Battery	26
3.4 Maintaining the Lubrication System	26
3.4.1 Oil Recommendations	26
3.4.2 Changing Engine Oil and Filter	27
3.5 Maintaining the Fuel System	29
3.5.1 Fuel Recommendations	29
3.5.2 Draining the Fuel Filter	29
3.5.3 Replacing Fuel Filter	30
3.5.4 Priming the Fuel System	31
3.6 Maintaining the Cooling System	31
3.6.1 Cooling System	32
3.6.2 Cooling System	33
3.6.3 Pressure Cap	34
3.6.4 Coolant Hoses	34
3.6.5 Siphon Break	34
3.6.6 Coolant Recommendations	35
3.6.7 Replenishing Normal Coolant Loss	36
3.6.8 Refilling Cooling System	36
3.6.9 Draining and Cleaning Cooling System	36
3.6.10 Heat Exchanger	37
3.6.11 Zinc Anode	39
3.6.12 Replacing the Thermostat	39
3.6.13 Replacing Raw Water Pump Impeller	40
3.6.14 Adjusting V-Belt Tension	42
3.6.15 Replacing V-Belt When PTO Equipped	43
3.7 Storing the Generator Set	43
3.8 Cold Temperature Storage	43
3.9 Returning the Generator Set to Service	43
4. GENERATOR SET CONTROL	45
4.1 Overview	45
4.2 Controller	45
4.2.1 Major Functions of Generator Set Controller	45
4.2.2 Control Block Diagram	47
4.2.3 Connectors	48
4.2.4 Removal/Replacement	48
4.2.5 Configuring Generator Set Controller Using Digital Display	49
4.2.6 Configuring Generator Set Controller Using Control Switch	50
4.3 Control Switch Schematic	51
4.4 Control Relays	51
4.5 Master Hour Meter (M11)	52
4.5.1 Master Hour Meter (M11)	52
4.6 Emergency Stop Switch/Circuit Breaker	52

4.7 DC Circuit Breaker	52
4.8 Engine Oil Pressure Sensor (E1).....	52
4.8.1 Oil Pressure Sensor (E1).....	53
4.8.2 Oil Pressure Sensor (E1).....	53
4.9 Coolant Temperature Sender (E2)	53
4.9.1 Coolant Temperature Sender (E2).....	54
4.9.2 Coolant Temperature Sender (E2).....	54
4.10 High Exhaust Temperature Switch (S5)	54
4.10.1 High Exhaust Temperature Switch (S5)	55
4.10.2 High Exhaust Temperature Switch (S5)	55
4.11 Raw Water Flow Switch (S6).....	56
4.11.1 Raw Water Flow Switch (S6)	56
4.11.2 Raw Water Flow Switch (S6)	57
4.12 Low Coolant Level Switch (S3).....	57
4.12.1 Low Coolant Level Switch (S3).....	58
4.12.2 Low Coolant Level Switch (S3).....	58
4.13 Glow Plug Relay (K3)	58
4.14 Starter Relay (K4)	59
4.15 Governor Actuator (A12).....	59
4.15.1 Governor Actuator.....	60
4.15.2 Governor Actuator.....	60
4.16 Network Interface Module (NIM).....	61
4.16.1 NIM Mounting Location	61
4.16.2 NIM Configuration Jumpers	61
4.16.3 Troubleshooting LEDs.....	62
4.16.4 Troubleshooting Network	63
4.17 NMEA 2000 Network Protocol	63
5. ENGINE AND ACCESSORIES	65
5.1 Major Engine Service.....	65
5.2 Exhaust Manifold	65
5.3 Fuel System.....	67
5.3.1 Fuel System	68
5.3.2 Fuel Filter	68
5.3.3 Fuel Pump Test.....	68
5.3.4 Fuel Pump Removal and Installation	69
5.3.5 Fuel Fittings.....	69
5.3.6 Fuel Hose.....	69
5.3.7 Glow Plugs	69
5.4 Starter	70
5.4.1 Negative Ground Connection.....	70
5.4.2 Ground Isolation Relay (K9).....	70
5.4.3 Starter Motor Mounting	71
5.5 Raw Water Pump.....	71
5.6 Battery Charging Alternator	71
6. ALTERNATOR	73

6.1 Overview	73
6.1.1 Generator Stator and Winding Resistances	74
6.2 Winding Insulation Resistance Test Procedure	75
6.3 Winding Resistance Test Procedure	75
6.4 Break-Out Tool 300-5512	75
6.5 Exciter Stator	76
6.5.1 Winding Insulation Resistance	76
6.5.2 Winding Resistance	76
6.5.3 Exciter Stator and End Bell	76
6.6 Exciter Rotor	77
6.6.1 Winding Insulation Resistance	77
6.6.2 Winding Resistance	77
6.7 Rotating Rectifiers	77
6.8 Main Rotor	79
6.8.1 Winding Insulation Resistance	79
6.8.2 Winding Resistance	80
6.8.3 Rotor Assembly	81
6.9 Main Stator	81
6.9.1 Winding Insulation Resistance	81
6.9.2 Winding Resistance	81
6.9.3 Quadrature Winding Insulation Resistance	82
6.9.4 Quadrature Winding Resistance	82
6.9.5 Winding to Winding Insulation Resistance	82
6.10 Generator Disassembly	83
6.11 Generator Reassembly	84
6.12 Reconnecting the Generator	85
6.13 Line Circuit Breakers	85
7. ADJUSTING AC OUTPUT VOLTAGE	87
7.1 Reconnecting Generator	87
7.1.1 Reconnection Label	87
7.2 Adjusting Voltage	88
7.3 Adjusting Voltage Using Digital Display	89
7.4 Adjusting Voltage Using Control Switch	89
8. TROUBLESHOOTING	91
8.1 Overview	91
8.2 Troubleshooting with Digital Display	91
8.3 Troubleshooting with Status Lamp	91
8.4 Troubleshooting Generator Set Faults	92
8.4.1 No Code - No Response at Digital Display or Control Switch	92
8.4.2 No Code - Starter Engages and Disengages	93
8.4.3 No Code - Starting Batteries do not Maintain a Charge	93
8.4.4 No Code - No AC Power When Generator Set is Running	94
8.4.5 Code No. 1 - High Engine Temperature	94
8.4.6 Code No. 2 - Low Oil Pressure	94
8.4.7 Code No. 3 - Service Check	95

8.4.8 Code No. 4 - Overcrank.....	95
8.4.9 Code No. 5 - Warning Shutdown due to CO	96
8.4.10 Code No. 7 - Loss of Raw Water Flow	96
8.4.11 Code No. 12 - High AC Voltage.....	97
8.4.12 Code No. 13 - Low AC Voltage.....	97
8.4.13 Code No. 14 - High AC Frequency	98
8.4.14 Code No. 15 - Low AC Frequency.....	98
8.4.15 Code No. 22 - Governor Overload.....	99
8.4.16 Code No. 23 - Faulty Oil Pressure Sender	99
8.4.17 Code No. 24 - Faulty Temperature Sender	100
8.4.18 Code No. 27 - Loss of AC Voltage Sense	100
8.4.19 Code No. 29 - High Battery Voltage	100
8.4.20 Code No. 32 - Starting Fault.....	100
8.4.21 Code No. 35 - Control Card Failure - EE.....	101
8.4.22 Code No. 36 - Unknown Shutdown	101
8.4.23 Code No. 37 - Invalid Generator Set Configuration.....	102
8.4.24 Code No. 38 - Field Overload	102
8.4.25 Code No. 41 - Generator Rotor Fault	102
8.4.26 Code No. 43 - Control Card Failure - RAM.....	103
8.4.27 Code No. 45 - Speed Sense Lost.....	103
8.4.28 Code No. 57 - Overprime.....	103
8.4.29 Code No. 58 - High Exhaust Temperature	103
8.4.30 Code No. 59 - Low Coolant Level.....	104
8.4.31 Code No. 61 - External Shutdown	104
9. SPECIFICATIONS	105
9.1 13.5 MDKDP, 17.5 MDKDR, 19 MDKDV.....	105
9.2 17 MDKDP, 21.5 MDKDR.....	107
9.3 22.5 MDKDT, 27 MDKDU, 29 MDKDS.....	110
10. MAINTENANCE RECORD	113
APPENDIX A. WIRING DIAGRAMS	115
A.1 Wiring Drawing	117
APPENDIX B. OUTLINE DRAWINGS	121
B.1 MDKDP, MDKDR, MDKDV Outline Drawing.....	123
B.2 MDKDS, MDKDT, MDKDU Outline Drawing.....	126
APPENDIX C. WIRING HARNESSSES.....	129
C.1 MDKD Wiring Harnesses	131



This page is intentionally blank.



1 Safety Precautions

1.1 Overview

Thoroughly read the Operator Manual before operating the generator set. It contains important instructions that should be followed during operation and maintenance. Safe operation and top performance can only be achieved when equipment is properly operated and maintained. The owners and operators of the generator set are solely responsible for its safe operation.

Generator set operation, maintenance, and installation must comply with all applicable local, state, and federal codes and regulations. Electricity, fuel, exhaust, moving parts, and batteries present hazards which can result in severe personal injury or death. Only trained and experienced personnel with knowledge of fuels, electricity, and machinery hazards shall perform generator set installation or adjustment procedures. Also, only trained and experienced personnel with knowledge of fuels, electricity, and machinery hazards shall remove, dismantle, or dispose of the generator set.

SAVE THESE INSTRUCTIONS.

WARNING

This generator set is not a life support system. It can stop without warning. Children, persons with physical or mental limitations, and pets could suffer personal injury or death. A personal attendant, redundant power, or alarm system must be used if generator set operation is critical.

WARNING

This generator set is not be the main source of power for communication and steering systems. It can stop without warning.

1.2 Precaution Symbols

The following symbols used in this manual alert you to potential hazards to operator, maintenance personnel, and equipment.

DANGER

Indicates a hazardous situation that, if not avoided, will result in death or serious injury.

WARNING

Indicates a hazardous situation that, if not avoided, could result in death or serious injury.

CAUTION

Indicates a hazardous situation that, if not avoided, could result in minor or moderate injury.

NOTICE

Indicates information considered important, but not hazard-related (e.g., messages relating to property damage).

1.3 General Safety Precautions

⚠ WARNING

Hot, moving, and electrically live parts can cause severe personal injury or death. Keep children away from the generator set.

⚠ WARNING

Hot, moving, and electrically live parts can cause severe personal injury or death. Only trained and experienced personnel should make adjustments while the generator set is running.

⚠ WARNING

*Electrical Generating Equipment
Incorrect operation can cause severe personal injury or death.
Do not operate equipment when fatigued, or after consuming any alcohol or drug.*

⚠ WARNING

*Electrical Generating Equipment
Incorrect operation and maintenance can result in severe personal injury or death
Make sure that only suitably trained and experienced service personnel perform electrical and/or mechanical service.*

⚠ WARNING

*Moving Parts
Moving parts can cause severe personal injury.
Use extreme caution around moving parts. All guards must be properly fastened to prevent unintended contact.*

⚠ WARNING

Running the generator set without the cover or service door can cause severe personal injury or equipment damage. Do not operate the generator set with the cover or service doors removed.

⚠ WARNING

*Hot Pressurized Liquid
Contact with hot liquid can cause severe burns.
Do not open the pressure cap while the engine is running. Let the engine cool down before removing the cap. Turn the cap slowly and do not open it fully until the pressure has been relieved.*

⚠ WARNING

*Hot Surfaces
Contact with hot surfaces can cause severe burns.
Wear appropriate PPE when working on hot equipment and avoid physical contact with hot surfaces.*

⚠ WARNING**Combustible Liquid**

Ignition of combustible liquids is a fire or explosion hazard which can cause severe burns or death.

Do not store fuel, cleaners, oil, etc., near the generator set.

⚠ WARNING**Combustible Liquid**

Ignition of combustible liquids is a fire or explosion hazard which can cause severe burns or death.

Do not use combustible liquids like ether.

⚠ WARNING**Toxic Hazard**

Ethylene glycol, used as an engine coolant, is toxic to humans and animals.

Wear appropriate PPE. Clean up coolant spills and dispose of used coolant in accordance with local environmental regulations.

⚠ WARNING**Toxic Hazard**

Used engine oils have been identified by some state and federal agencies to cause cancer or reproductive toxicity.

Do not ingest, breathe the fumes, or contact used oil when checking or changing engine oil. Wear protective gloves and face guard.

⚠ WARNING

Inhalation of carbon monoxide can cause severe personal injury or death. Test and confirm that all carbon monoxide detectors are working in accordance with the manufacturer's instructions or owner's manual prior to every startup, and after 8 hours of running.

⚠ WARNING**Toxic Gases**

Substances in exhaust gases have been identified by some state and federal agencies to cause cancer or reproductive toxicity.

Do not breathe in or come into contact with exhaust gases.

⚠ DANGER**Accidental or remote starting.**

Accidental starting of the generator set while working on it can cause severe personal injury or death

To prevent accidental or remote starting while working on the generator set, disconnect the negative (-) battery cable at the battery using an insulated wrench.

⚠ CAUTION

Unsecured or loose fasteners can cause equipment damage. Make sure all fasteners are secure and properly torqued.

⚠ CAUTION

Oily rags and other material can cause fire and restrict cooling. Keep the generator set, drip pan, and compartment clean.

⚠ WARNING**Fire Hazard**

Accumulated grease and oil are a fire hazard. Fire can cause severe burns or death. Keep the generator set and the surrounding area clean and free from obstructions. Repair oil leaks promptly.

NOTICE

Keep multi-class ABC fire extinguishers handy. Class A fires involve ordinary combustible materials such as wood and cloth. Class B fires involve combustible and flammable liquid fuels and gaseous fuels. Class C fires involve live electrical equipment. (Refer to NFPA No. 10 in applicable region.)

1.4 Electrical Shocks and Arc Flashes Can Cause Severe Personal Injury or Death

⚠ WARNING**Electric Shock Hazard**

Voltages and currents present an electrical shock hazard that can cause severe burns or death. Contact with exposed energized circuits with potentials of 50 Volts AC or 75 Volts DC or higher can cause electrical shock and electrical arc flash. Refer to standard NFPA 70E or equivalent safety standards in corresponding regions for details of the dangers involved and for the safety requirements.

Guidelines to follow when working on de-energized electrical systems:

- Use proper PPE. Do not wear jewelry and make sure that any conductive items are removed from pockets as these items can fall into equipment and the resulting short circuit can cause shock or burning. Refer to standard NFPA 70E for PPE standards.
- De-energize and lockout/tagout electrical systems prior to working on them. Lockout/Tagout is intended to prevent injury due to unexpected start-up of equipment or the release of stored energy. Please refer to the lockout/tagout section for more information.
- De-energize and lockout/tagout all circuits and devices before removing any protective shields or making any measurements on electrical equipment.
- Follow all applicable regional electrical and safety codes.

Guidelines to follow when working on energized electrical systems:

NOTICE

It is the policy of Cummins Inc. to perform all electrical work in a de-energized state. However, employees or suppliers may be permitted to occasionally perform work on energized electrical equipment only when qualified and authorized to do so and when troubleshooting, or if de-energizing the equipment would create a greater risk or make the task impossible and all other alternatives have been exhausted.

NOTICE

Exposed energized electrical work is only allowed as per the relevant procedures and must be undertaken by a Cummins authorized person with any appropriate energized work permit for the work to be performed while using proper PPE, tools and equipment.

In summary:

- Do not tamper with or bypass interlocks unless you are authorized to do so.
- Understand and assess the risks - use proper PPE. Do not wear jewelry and make sure that any conductive items are removed from pockets as these items can fall into equipment and the resulting short circuit can cause shock or burning. Refer to standard NFPA 70E for PPE standards.
- Make sure that an accompanying person who can undertake a rescue is nearby.

1.5 Generator Voltage Is Deadly

- Generator electrical output connections must be made by a trained and experienced electrician in accordance with applicable codes.
- Use caution when working on live electrical equipment. Remove all jewelry, make sure clothing and shoes are dry, stand on a dry wooden platform or rubber insulating mat, and use tools with insulated handles.

1.6 Engine Exhaust Is Deadly

- Properly working carbon monoxide detectors must be located in all living areas of the boat.
- Never occupy the boat while the generator set is running unless the boat is equipped with properly working marine carbon monoxide detectors.
- The exhaust system must be installed in accordance with the generator set Installation Manual and be free of leaks.
- Prior to every startup and after every eight hours of running, all carbon monoxide detectors must be tested and confirmed to be working in accordance with the manufacturer's instructions or owner's manual.
- Make sure the bilge is adequately ventilated with a power exhaustor or blower.
- Inspect for exhaust leaks at every startup and after every eight hours of operation.
- For more information about carbon monoxide see American Boat and Yacht Council (ABYC) publication TH-22—*Educational Information About Carbon Monoxide*.

1.7 Diesel Fuel is Combustible

- Do not smoke or turn electrical switches on or off where fuel fumes are present or in areas sharing ventilation with fuel tanks or equipment. Keep flames, sparks, pilot lights, arc-producing equipment, and all other sources of ignition well away.
- Fuel lines must be secured, free of leaks, and separated or shielded from electrical wiring.

1.8 Battery Gas is Explosive

- Wear splash-proof safety glasses.
- Do not smoke or permit flames or sparks to occur near the battery at any time or anywhere near the generator set.
- To reduce arcing when disconnecting or reconnecting battery cables, always disconnect the negative (–) battery cable first and reconnect it last.

1.9 Moving Parts Can Cause Severe Personal Injury Or Death

- Do not wear loose clothing or jewelry near moving parts such as PTO (power take-off) shafts, fans, belts, and pulleys.
- Keep hands away from moving parts.
- Keep protective guards in place over fans, belts, pulleys, and other moving parts.

1.10 Flammable Vapor Can Cause a Diesel Engine to Overspeed

⚠ WARNING

Flammable vapor can cause an engine to overspeed and become difficult to stop, resulting in possible fire, explosion, severe personal injury, and death. Do not operate a diesel- or gasoline-powered generator set where a flammable vapor environment can be created by fuel spill, leak, etc.

The owners and operators of the generator set are solely responsible for operating the generator set safely.

1.11 Hazards of Carbon Monoxide

⚠ WARNING

Engine-driven generators can produce harmful levels of carbon monoxide causing nausea, fainting, or death. It is possible to be harmed by this poisonous gas despite good generator set maintenance and proper ventilation.

1.11.1 Carbon Monoxide Poisoning

Carbon Monoxide (CO) is an odorless, colorless, tasteless, and non-irritating gas. You cannot see it or smell it. Exposure, even to low levels of CO, for a prolonged period can lead to asphyxiation (lack of oxygen) resulting in death.

Mild effects of CO poisoning include:

- eye irritation
- dizziness
- sleepiness
- headaches
- fatigue
- inability to think clearly

More extreme symptoms include:

- vomiting
- seizures
- collapse

1.11.2 Special Risks of CO on Boats

Depending on air temperature and wind, CO can accumulate between hulls, under an overhanging deck or rear swimming platform, and in and around the boat. A swimmer can be exposed to lethal levels of CO when the generator set is running. Passengers on deck and in the living quarters can also be exposed, especially when the boat is docked, beached, or tied to a neighboring boat.

The risk of exposure to CO can be multiplied greatly by the "station wagon" effect, obstructions that block exhaust dissipation, and infiltration from neighboring boats. To protect against all three situations, it is recommended that reliable and approved marine CO detector alarms be installed on your boat.

- **The Station Wagon Effect:** A boat pushes aside the air through which it is moving, causing a zone of low pressure in the back of the boat and cabins into which exhaust gases can be drawn (see figure below). A breeze across an anchored boat can have the same effect. Opening doors and windows so that air can flow through the boat can reduce the effect.

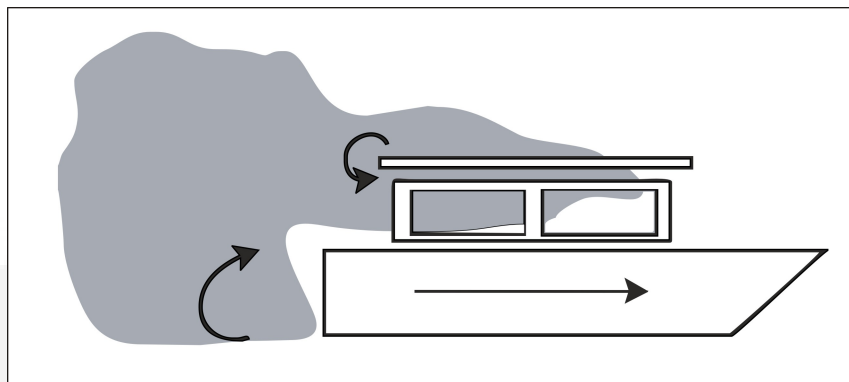

FIGURE 1. STATION WAGON EFFECT

- **Obstructions:** Anchoring near a large object such as a boat house or sea wall, or in a confined space such as a canyon, can cause exhaust gases to accumulate in and around the boat despite good generator set maintenance and proper ventilation. Don't run the generator set when anchored in such places.
- **Exhaust from Neighboring Boats:** When boats are anchored in close quarters, exhaust from neighboring boats can accumulate in and around yours.

1.11.3 Protection From CO Poisoning

- Constantly watch for swimmers when the generator set is running.
- Make sure exhaust cannot get under the deck, between hulls, or enter the living quarters through a window, vent, or door.
- Make sure all CO detectors are working properly.
- Pay attention to the signs of CO poisoning.
- Check the exhaust system for corrosion, obstruction, and leaks each time you start the generator set and every eight hours if you run it continuously.

1.12 Substances Hazardous to Health

Generator sets use substances, and emit and create wastes, that can cause health risks. Generator set operators must use appropriate personal protective equipment (such as clothing, gloves, protective glasses, goggles, and respiration equipment) when lungs, eyes, or skin are exposed to fuel, oil, coolant, wet batteries, grease, cleaning agents, or other substances. Use appropriate containers for transport, storage, and disposal of waste substances. Follow local regulations for disposal and recycling.

1.12.1 Antifreeze (Fleetguard - ES Compleat and EG Premix)

This antifreeze is also known as an ethylene glycol based coolant, summer coolant, coolant additive. It is a purple-colored viscous liquid with a mild chemical odor, is soluble in water, and is harmful under certain conditions. It contains ethylene glycol and diethylene glycol. Ethylene glycol is a potentially hazardous constituent.

The substance has a boiling point of 107 °C (224.6 °F) and a flash point of 121 °C (249.8 °F).

It is used as an engine coolant additive and can be found in engine cooling systems and heat exchangers. Installers, operators, and maintainers are likely to encounter this substance.

1.12.1.1 Hazardous Reactions

Ethylene glycol is combustible when exposed to heat or flame and can react vigorously with oxidants.

- It is a moderate explosive hazard in the form of vapor when exposed to heat or flame. Hazardous products resulting from combustion or decomposition include carbon monoxide, carbon dioxide, and acrid smoke. Self-contained breathing apparatus must be worn in the event of fume build up.
- It is incompatible with sulfuric acid, nitric acid, caustics, and aliphatic amines. Avoid any strong oxidizing agents.
- It may cause neurological signs and symptoms, kidney damage, and is a skin and eye irritant.
- It is very toxic in particulate form upon inhalation.
- It is harmful if swallowed. A lethal dose for humans is reported to be 100 ml.

1.12.1.2 Protective Measures

Refrain from eating, drinking, or smoking when using the product. Adopt a high standard of personal hygiene. In case of skin contact, wash immediately with soap and water.

Ensure good ventilation and avoid heat sources. Avoid breathing mist. If there is a risk of vapor or particulate, use a suitable organic vapor mask.

Eye protection, gloves, overalls, and an impervious apron should be worn. Avoid contamination inside the gloves. If overalls become contaminated, discontinue use and clean thoroughly.

1.12.1.3 Storage and Transport

Store and transport only in correctly marked containers. Keep containers closed when not in use. Keep cool, out of sunlight, and away from naked flames and strong acids. Do not freeze. Store well away from food-stuffs and drinking water. Take special care to avoid discharge into drains, sewers, and water-course.

Contain leaks and spills with sand, earth, or non-combustible absorbent material to prevent entry of substance into drains (sewage systems), water-courses, and land. Eliminate all ignition sources. Use a plastic shovel to transfer to a suitable container. Dispose of unwanted or absorbed substance through an authorized contractor to a licensed site.



1.12.1.4 Emergency Action

- Fire - Fire fighters are to use self contained breathing apparatus. Keep fire-exposed containers cool. Prevent run-off from entering waterways, drains, and drinking water supplies. Extinguishing media: CO₂, alcohol resistant foam, dry powder, or water spray.
- Ingestion - Toxic by ingestion. If swallowed, contact a doctor or poison control center. Induce vomiting only under the advice of a doctor or poison control center. Delayed treatment may result in fatality.
- Inhalation (of vapor) - Remove from further exposure. In case of irritation to lungs or throat, seek medical advice.
- Aspiration (inhalation of liquid) - Obtain immediate medical assistance.
- Eyes - Flush copiously with water or preferably eye-wash solution for at least five minutes. Seek medical advice.
- Skin - Wash thoroughly with soap and water and seek medical attention if irritation develops. Change clothing if necessary and wash clothing before re-use.
- Spillage - Soak up using an absorbent material and dispose of as directed under Storage and Transport.

1.12.2 Gas Oil

This product is also known as red diesel, fuel oil, and type A1 or A2. It can be pale red or clear liquid with a characteristic mild odor. It contains catalytically cracked oil, petroleum distillates, quinizarin, and gas oil maker dye red. The catalytically cracked oil and petroleum distillates are potentially hazardous constituents.

The substance has an initial boiling point of 180 °C (345 °F), a flash point greater than 56 °C (132.8 °F), a vapor pressure less than 0.7 mm Hg at 20 °C (68 °F), and has negligible solubility in water.

It is used as a fuel for off-road diesel powered vehicles and stationary engines and can be found in fuel tanks, pipes, and injection systems. The substance should not be used for any other purpose without contacting the manufacturer or supplier. Installers, operators, and maintainers are likely to encounter this substance.

1.12.2.1 Hazardous Reactions

This liquid is flammable. Avoid smoking, heat sources - such as welding and naked flames - sparks, and static electricity build-up. Thermal decomposition products are hazardous, containing CO_x, NO_x, and SO_x compounds.

The vapor is explosive. High vapor concentrations can cause respiratory irritation, dizziness, nausea, and loss of consciousness. Excessive and prolonged exposure to the mist can cause chronic inflammatory reaction of the lungs and a form of pulmonary fibrosis.

Avoid strong oxidizing agents such as chlorates which may be used in agriculture.

Gas oil is slightly irritating to the skin and has a de-fatting action. Toxicity following single exposure to a high level of gas oil is of low importance. Prolonged, repeated skin contact may de-fat the skin resulting in possible skin irritation and dermatitis. In some cases warty, cancerous growths have occurred.

1.12.2.2 Protective Measures

Ensure good ventilation and avoid heat sources. Observance of good housekeeping rules will ensure general safety. Do not smoke. Avoid breathing mist.

When working on or testing injection equipment, special care is required to avoid perforation of skin by high pressure fuel. Use eye protection in the event of suspected high pressure leak.

Adopt a high standard of personal hygiene. In the case of skin contact, wash well with soap and water.

Use gloves, overalls, and eye protection if there is a risk of splashing. Use oil-impervious gloves and avoid contamination inside the gloves. If overalls become contaminated, discontinue use and clean thoroughly. Contaminated clothing should be removed, soaked with water, and laundered before re-use.

No special respiratory precautions are necessary in normal use.

Do not use as a solvent for removing dirt and grease, etc, from skin.

1.12.2.3 Storage and Transport

Store and transport only in correctly marked containers. Keep containers closed when not in use. Keep cool, out of sunlight, and away from naked flames. Electrical continuity is required between the transport and storage vessels during product transfer.

Contain leak or spill with sand, earth, or other suitable material, and prevent entry of substance into drainage (sewage system), water-courses, and land. Dispose of unwanted or absorbed substance through an authorized contractor to a licensed site.

Inform fire and local authorities should the product reach waterways, drains, etc.

1.12.2.4 Emergency Action

- Fire - Avoid making sparks. Fire fighters are to use self-contained breathing apparatus. Keep fire-exposed containers cool, using water fog or spray. Prevent run-off from entering waterways, drains, and drinking water supplies.
 - Extinguishing media for large fire: Foam or water fog. Never use water jet.
 - Extinguishing media for small fire: Foam or dry powder, AAAF, CO₂, sand, earth.
- Ingestion - Do not induce vomiting. Wash mouth out with water and send to hospital immediately.
- Inhalation (of vapor) - Remove from further exposure. Obtain medical assistance immediately.
- Aspiration (inhalation of liquid) - If, following ingestion of gas oil, vomiting occurs, there is danger of aspiration into the lungs. This would cause intense local irritation and chemical pneumonitis that can be fatal. Obtain immediate medical assistance.
- Eyes - Irrigate copiously with water or preferably eye-wash solution for at least five minutes. If irritation persists seek medical advice.
- Skin - Wash thoroughly with soap and water. Change clothing if necessary. If high pressure injection has occurred prompt surgical attention is required.
- Spillage - Absorb using sand, earth, or other suitable material. Dispose of unwanted or absorbed flammable material as directed under Storage and Transport.

1.12.3 Lubricant Oil - Premium Blue E 15W40

Also known as oil, lube oil, sump oil. New oil is a dark, viscous liquid with a slight characteristic odor. The base oil contains distillates (petroleum) and solvent-dewaxed heavy paraffinic. It is not classified as dangerous according to Directive 1999/45/EC and its amendments, and is not classified according to the EU regulations.

It has a boiling point greater than 150° C (302 °F), and a flash point Open Cup of 220° C (438 °F) (Cleveland) and is insoluble in cold water.

It is used in engine lubricant oil systems, sump pan and filters, make-up tanks, and piping systems as a lubrication oil for use in a wide range of diesel engines operating under severe conditions. Installers, operators, and maintainers are likely to encounter this product.

1.12.3.1 Hazardous Reactions

This product is stable, although slightly re-active, with oxidizing agents. Results of decomposition are carbon oxides (CO, CO₂) and water.

Although harmful if ingested (swallowed) or aspirated (breathed in), repeated or prolonged exposure is not known to aggravate medical conditions.

Used oil may contain harmful combustion by-products and un-burnt fuel that will cause skin reactions as detailed for fuel. Particular care must be taken if oil from a severely overheated engine is handled. Use impervious gloves, lab coat, and safety glasses. Do not breathe vapor or spray.

1.12.3.2 Protective Measures

Ensure good ventilation and avoid heat sources.

Adopt a high standard of personal hygiene. In case of skin contact, wash thoroughly with soap and water.

Use safety glasses, impervious gloves, and lab coat. Avoid contamination inside the gloves. If overalls become contaminated, discontinue use and clean thoroughly.

No special respiratory precautions are necessary in normal use. Do not breathe vapor or spray when handling hot materials.

1.12.3.3 Storage and Transport

Store and transport only in correctly marked containers. Keep containers tightly sealed when not in use. Keep in cool, well ventilated area, out of sunlight and away from naked flames. Store well away from food-stuffs and drinking water.







Wear splash goggles, full suit, boots, and gloves. Absorb leaks or spills with an inert material and dispose of unwanted or absorbed substance through an authorized contractor to a licensed site. Finish cleaning by spreading water on the contaminated surface and allow to evacuate through the sanitary system.



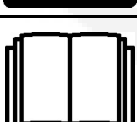

1.12.3.4 Emergency Action

- Fire - Fire-fighters are to use self contained breathing apparatus and full turnout gear. Keep fire-exposed containers cool.
 - Extinguishing media for large fire: Use water spray, fog or foam. Do not use water jet.
 - Extinguishing media for small fire: Use dry chemical powder or CO₂.
- Ingestion - Do not induce vomiting. Obtain medical advice immediately.
- Inhalation (of vapor) - Remove from further exposure. Obtain medical attention.
- Aspiration (inhalation of liquid) - Obtain immediate medical assistance.
- Eyes - Flush copiously with water or preferably eye-wash solution for at least fifteen minutes. Obtain medical advice.
- Skin - Wash thoroughly with soap and water. Obtain medical advice if irritation develops. Change clothing if necessary and wash before re-use.
- Spillage - Absorb with an inert material and dispose of as directed under Storage and Transport.

1.13 Generator Set Warning Labels

Warning signs are provided on the generator set at or near the point of risk. To avoid injury, always take the necessary precautions as indicated on the sample signs shown below.

	Caution or Warning. Indicates a risk of personal injury.
	Caution or Warning of Temperature Hazard. Indicates a risk of personal injury from high temperature.
	Caution or Warning of High Voltage Hazard. Indicates a risk of personal injury from electric shock or electrocution.
	Caution or Warning of Engine Coolant Pressure Hazard. Indicates a risk of personal injury from hot pressurized engine coolant.
	Caution or Warning. Indicates to read Operator Manual for additional information.
	Caution or Warning of No Step. Indicates a risk of personal injury or equipment damage from stepping on equipment.

	Caution or Warning of Combustion or Explosion Hazard. Indicates a risk of personal injury from explosion.
	Caution or Warning of Belt and Rotating Part Hazard. Indicates a risk of personal injury from entanglement in moving parts.
	Caution or Warning of Chemical (ingestion or burn) Hazard. Indicates a risk of personal injury or asphyxiation from poisonous fumes or toxic gases.
	Caution or Warning of High Voltage or Current Source Hazard. Indicates a risk of personal injury from electrical shock or electrocution.
	Caution or Warning of Fan and Rotating Part Hazard. Indicates a risk of personal injury from entanglement in moving parts.

2 Introduction

WARNING

Hazardous Voltage

Contact with high voltages can cause severe electrical shock, burns, or death.

Make sure that only a trained and experienced electrician makes generator electrical output connections, in accordance with the installation instructions and all applicable codes.

WARNING

Electrical Generating Equipment

Faulty electrical generating equipment can cause severe personal injury or death.

Generator sets must be installed, certified, and operated by trained and experienced person in accordance with the installation instructions and all applicable codes.

2.1 About This Manual

This is the Service Manual for the generator set or sets listed on the front cover.

The information contained within the manual is based on information available at the time of going to print. In line with Cummins Power Generation policy of continuous development and improvement, information may change at any time without notice. The users should therefore make sure that before commencing any work, they have the latest information available. The latest version of this manual is available on QuickServe Online (<https://qsol.cummins.com/info/index.html>).

This manual includes generator set specifications, troubleshooting resolutions for all fault codes, maintenance schedule, service and maintenance procedures for the generator set control, engine, accessories, and generator as well as adjusting the AC output voltage and changing the generator set frequency .

See the Parts Manual for part identification numbers and required quantities. Genuine Cummins Onan replacement parts are recommended for best results.

2.1.1 Warning - Generator Set Not Ignition Protected

WARNING

The generator set or sets included in this manual are not ignition protected and shall not be used in a flammable vapor environment.

WARNING

Within the Parts Manual, MC parts are marine critical and must comply with boating safety ignition protection, backfire, fire resistance, exhaust system integrity, or other requirements established by regulatory agencies, such as the U.S. Coast Guard, ABYC, and ISO. When marine critical parts are replaced for any reason, use Cummins Onan parts that are identified with the part numbers in the appropriate Parts Manual.

2.2 Related Literature

Before any attempt is made to operate the generator set, the operator should take time to read all of the manuals supplied with the generator set, and to familiarize themselves with the warnings and operating procedures.

CAUTION

A generator set must be operated and maintained properly if you are to expect safe and reliable operation. The Operator manual includes a maintenance schedule and a troubleshooting guide. The Health and Safety manual must be read in conjunction with this manual for the safe operation of the generator set:

- Health and Safety Manual (0908-0110)

The relevant manuals appropriate to your generator set are also available, the documents below are in English:

- Operator Manual (A046J600)
- Installation Manual (A046J598)
- Generator Service Manual (A046J602)
- Parts Manual MDKDP, MDKDR, MDKDV (A046L892)
- Parts Manual MDKDS, MDKDT, MDKDU (A046J604)
- Specification and Data Sheet MDKDP NAS-5897, MDKDR NAS-5898, MDKDV NAS-5902, MDKDS NAS-5899, MDKDT NAS-5900, and MDKDU NAS-5901 (for technical data specific to the generator set)
- Standard Repair Times - BT Family (0900-0625) (for MDKDP, MDKDR, MDKDV)
- Standard Repair Times - CD Family (0900-0634) (for MDKDS, MDKDT, MDKDU)
- Service Tool Manual (A043D529)
- Failure Code Manual (F1115C)
- Application Manual T-030, *Liquid Cooled Generator Sets* - for application information (A040S369)
- Engine Service Manual for Kubota V2003-E3BG (13.5 MDKDP) (981-0551)
- Engine Service Manual for Kubota V2403-M-E3BG (17.5 MDKDR and 19 MDKDV) (981-0551)
- Engine Service Manual for Kubota V2403-M-E4BG (17 MDKDP and 21.5 MDKDR) (A049P370)
- Engine Service Manual for Kubota V3300-E3BG (19 MDKDT, 22.5 MDKDT and 27 MDKDU) (981-0553)
- Engine Service Manual for Kubota V3300-E4BG (29 MDKDS) (A049P372)
- Warranty Manual (A040W374)
- Emissions Warranty Statement for Kubota (A048K395)

2.3 Model Identification

The generator set model name is found on the nameplate, which is mounted on the service side of the generator set. See figure below. Every character is significant (the last character of the model number is the specification letter, which is important for obtaining the right parts).

⚠ WARNING

Improper service or replacement of parts can lead to severe personal injury or death and damage to equipment and property. Service personnel must be qualified to perform electrical and mechanical service.

2.3.1 Nameplate Location

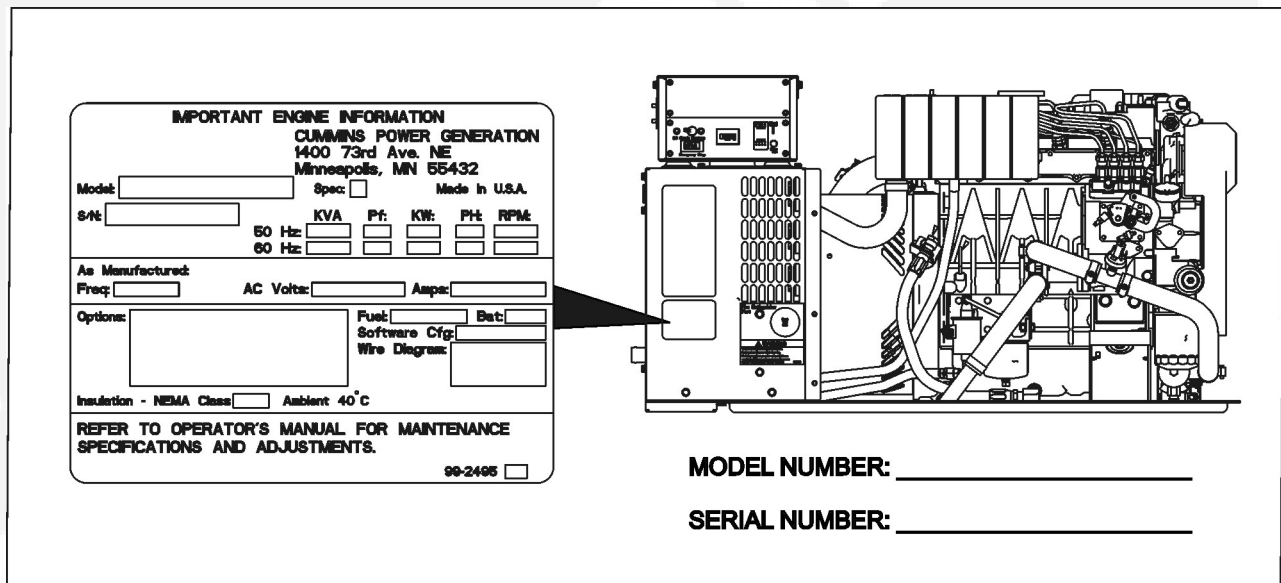

FIGURE 2. NAMEPLATE LOCATION

2.4 Emissions Label

The emissions label states compliance with applicable engine emissions regulations for US EPA certified models (17 MDKDP, 21.5 MDKDR, and 29 MDKDS). Refer also to the Federal Emissions Design And Defect Limited Warranty For C.I. Engine (Diesels) publication that was shipped in the same package as the Operator Manual.

NOTICE

The emissions warranty statement is for EPA certified only products.

2.4.1 Typical Emissions Label Location

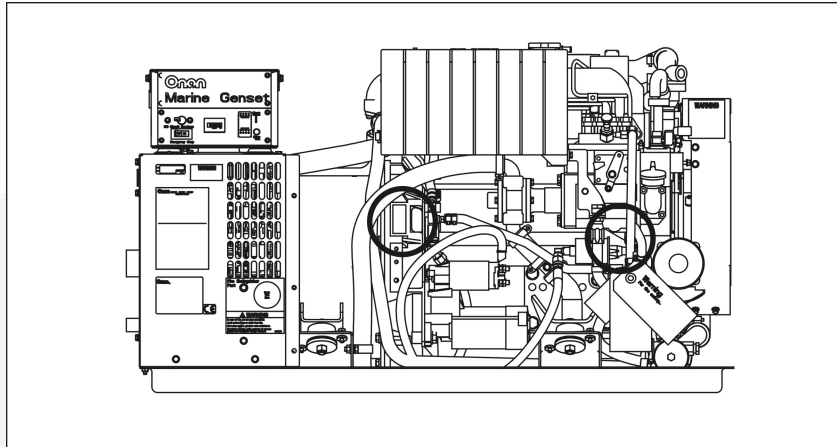

FIGURE 3. TYPICAL EMISSIONS LABEL LOCATIONS

2.5 Noise

Generator sets emit noise. As noise level and time of exposure increase, risk of hearing damage increases. [Chapter 9 on page 105](#) includes specific noise level information for these generator sets. Use personal hearing protection appropriate for your exposure to generator set noise.

When used in countries where compliance to the EU Noise directive is required: This generator set has not been evaluated and is not marked for use in open air. Install the generator set in accordance with the Installation Manual. Obey local noise restrictions when you operate the generator set.

2.6 Electromagnetic Compatibility Compliance

Generator sets emit and receive electromagnetic (radio frequency) energy. If the generator set affects operation of nearby devices, or nearby devices affect generator set operation, increase the distance between them.

When used in countries where compliance to the EMC directive is required: This generator set has been evaluated for use in the residential, commercial, and light industrial environments.

2.7 Build Standards

The generator set and its control system have been designed, constructed and tested generally in accordance with the following Standards where applicable.

Standard	Title
BS EN 1037:1995+a1:2008	Safety of machinery - Prevention of unexpected start up.
BS EN ISO 14121-1:2007	Safety of machinery. Risk assessment principles.
BS EN ISO 13857:2008	Safety of machinery. Safety distances to prevent hazard zones being reached by upper and lower limbs.

Standard	Title
BS EN 349:1993+A1:2008	Safety of machinery - Minimum gaps to avoid crushing parts on the human body.
BS EN 547-1:1996+A1:2008	Safety of machinery - Human body dimensions - Part 1: Principles for determining the dimensions required for openings for whole body access into machinery.
BS EN 547-2:1996+A1:2008	Safety of machinery - Human body dimensions - Part 2: Principles for determining the dimensions required for access openings.
BS EN 547-3:1996+A1:2008	Safety of machinery - Human body dimensions - Part 3: Anthropomorphic data.
BS EN 60204-1:2006+A1:2009	Safety of machinery. Electrical equipment of machines. General requirements.
BS EN 614-1:2006+A1:2009	Safety of machinery. Ergonomic design principles. Terminology and general principles.
BS EN 953:1997+A1:2009	Safety of machinery - Guards - General requirements for the design and construction of fixed and movable guards.
BS EN ISO 12100-1:2003+A1:2009	Safety of machinery. Basic concepts, general principles for design. Basic terminology, methodology
BS EN ISO 12100-2:2003+A1:2009	Safety of machinery. Basic concepts, general principles for design. Technical principles
BS EN ISO 13732-1:2008	Ergonomics of the thermal environment. Methods for the assessment of human responses to contact with surfaces. Hot surfaces
BS EN ISO 13849-1:2008	Safety of machinery - Safety-related parts of control systems
BS EN ISO 13850:2006	Safety of machinery - Emergency stop. Principles for design.
BS EN 61310-1:2008	Safety of machinery - Indication, marking and actuation - Part 1: Requirements for visual, auditory and tactile signals.
BS EN 61310-2:2008	Safety of machinery - Indication, marking and actuation - Part 2: Requirements for marking.
BS EN 61000-6-1:2007	Electromagnetic compatibility (EMC). Generic standards. Immunity standard for residential, commercial and light-industrial environments.
BS EN 61000-6-3:2007	Electromagnetic compatibility (EMC). Generic standards. Emission standard for residential, commercial and light-industrial environments.
BS EN 1299:1997+A1:2008	Mechanical vibration and shock - Vibration isolation of machines - Information for the application of source isolation
BS EN 1679-1:1998	Reciprocating internal combustion engines - Safety - Part 1: Compression ignition engines
BS EN 12601:2001	Reciprocating internal combustion engine driven generating sets - Safety



This page is intentionally blank.



3 Maintenance

3.1 Periodic Maintenance

Periodic maintenance is essential for top performance and long generator set life. Use the Periodic Maintenance Schedule below as a guide for normal periodic maintenance.

Maintenance, replacement, or repair of emission control devices and systems may be performed by any engine repair establishment or individual. However, warranty work must be completed by an authorized Cummins Onan service representative.

To help keep generator set maintenance regular and provide a basis for warranty claims, record maintenance performed, see [Chapter 10 on page 113](#).

3.1.1 Periodic Maintenance Schedule

TABLE 1. PERIODIC MAINTENANCE SCHEDULE

MAINTENANCE OPERATION	MAINTENANCE FREQUENCY									
	After First 50 Hrs	Every Day/8 Hrs	Every Month/100 Hrs	Every Year/200 Hrs	Every Year/350 Hrs	Every Year/500 Hrs	Every 800 hrs	Every 2 Years	Every 5 Years /2000 Hrs	
General Inspection ¹		x								
Check Engine Oil Level		x								
Drain Water From Fuel Filter			x							
Check Battery and Battery Connections ²			x							
Check V-Belt Tension ³			x							
Check Siphon Break			x							
Change Oil and Filter - All except MDKDS, MDKDT, and MDKDU ⁵	x			x						
Change Oil and Filter - Only MDKDS, MDKDT, and MDKDU ⁵	x				x					
Change Fuel Filter						x				
Inspect Zinc Anode						x				
Replace Raw Water Pump Impeller						x				
Adjust Valve Lash ⁴							x			
Replace Coolant, Pressure Cap, and Thermostat								x		
Inspect Generator Bearing ⁴									x	

1 - Includes inspection of Oil Level, Coolant Level, Fuel System, Exhaust System, Batteries and Battery Connections.
2 - See battery manufacturer's recommendations.
3 - Check for slippage, cracking, and wear.
4 - Must be performed by a qualified mechanic (authorized Cummins Onan Dealer).
5 - Perform twice as often when using high sulfur fuel. See Engine Oil Recommendations in the Maintenance chapter.

3.2 General Inspection

Inspect the following before the first start of the day and after every eight hours of operation.

- Battery Connections
- Oil Level
- Fuel System
- Coolant Level
- Raw Water System
- Exhaust System
- Mechanical System

Review the following figure for assistance in locating various service points.

3.2.1 Service Point Locations

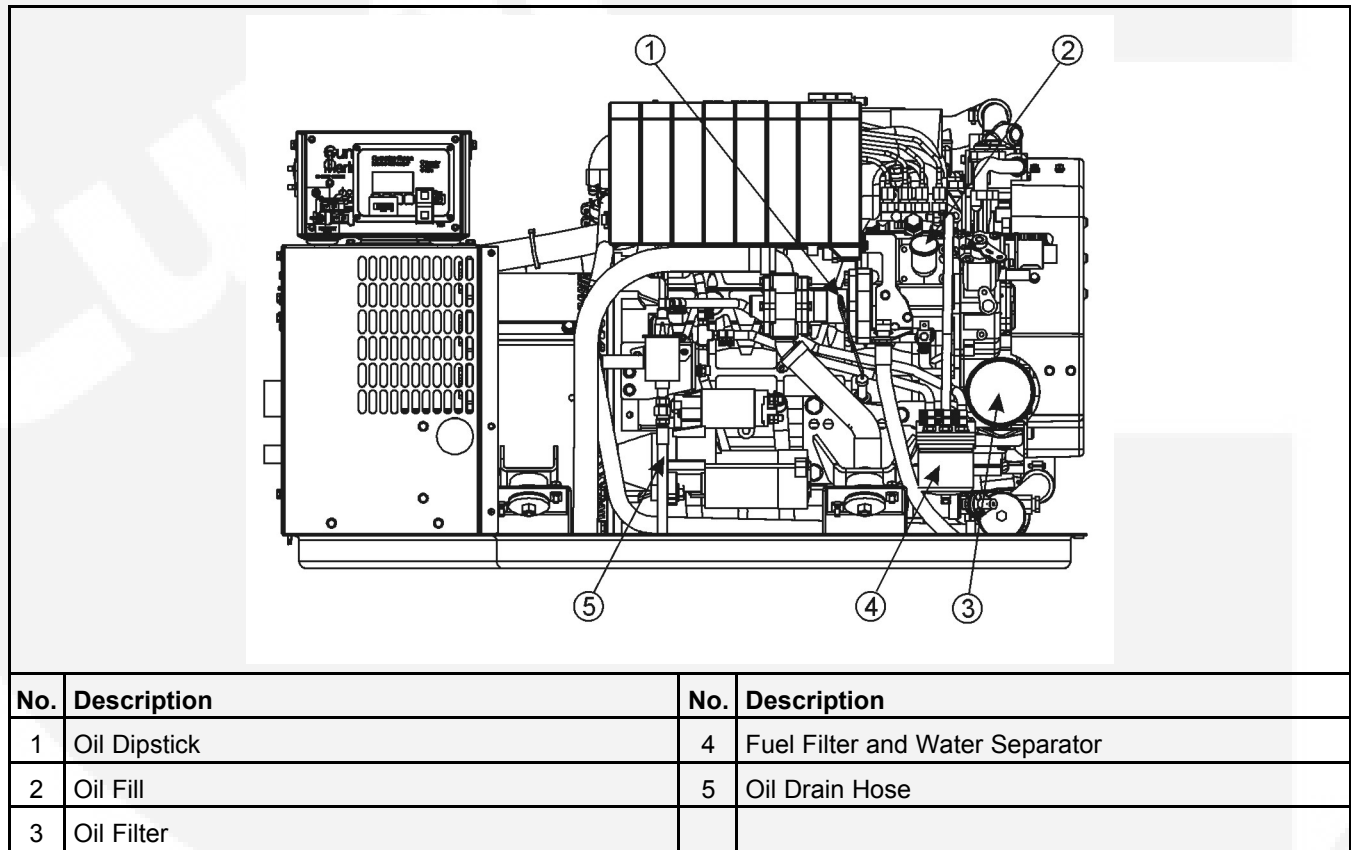

FIGURE 4. OIL AND FUEL SERVICE POINTS - MDKDP, MDKDR, MDKDV

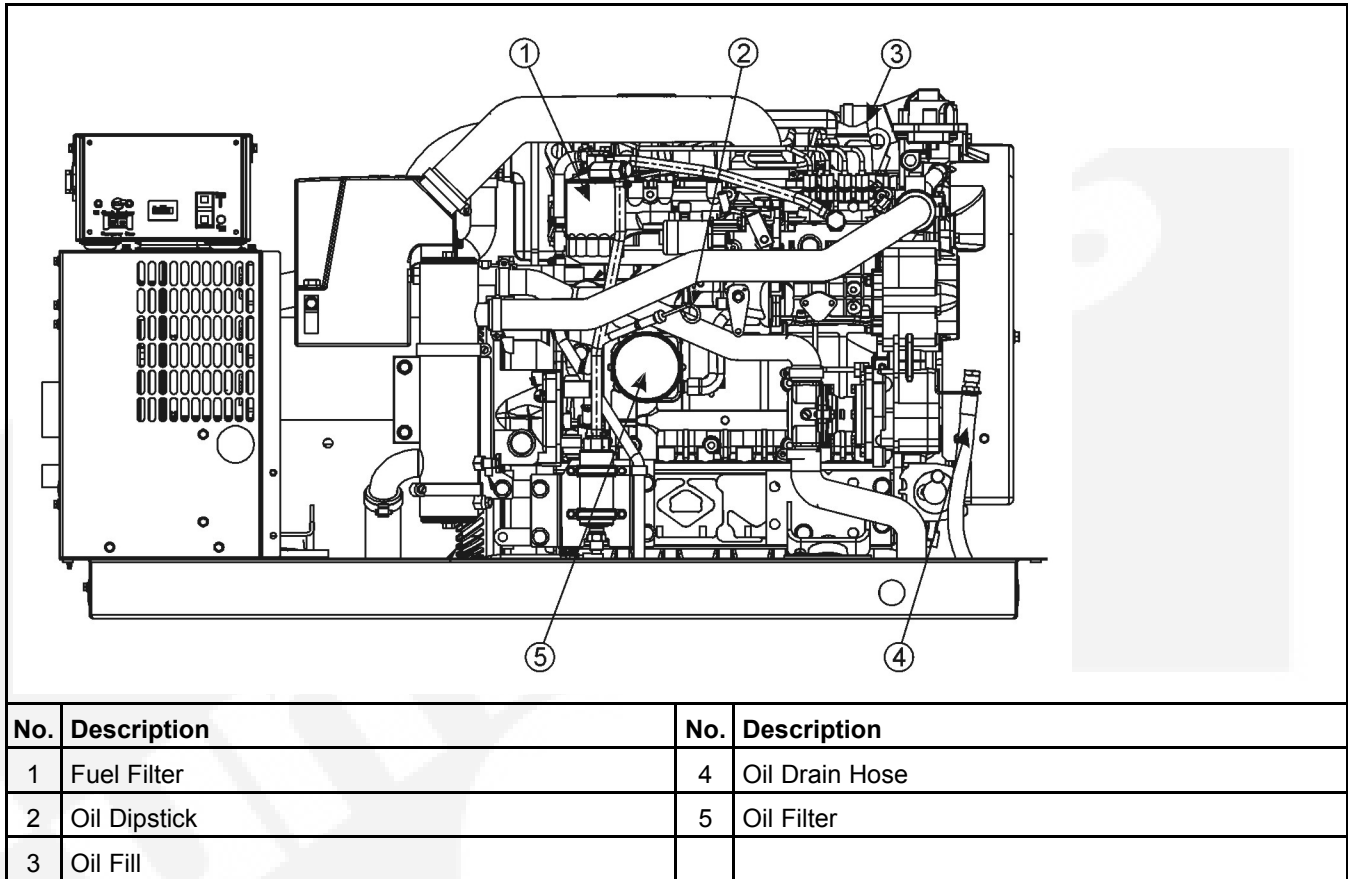

FIGURE 5. OIL AND FUEL SERVICE POINTS - MDKDS, MDKDT, AND MDKDU

3.2.2 Battery Connections

⚠ WARNING

Flames, sparks, or arcing at battery terminals, light switches, or other equipment can ignite battery gas, causing severe personal injury. Ventilate the battery area before working on or near a battery, wear safety glasses, and do not smoke. Turn work light on or off away from the battery. When performing maintenance procedures or when servicing a battery, stop the generator set and disconnect the charger before disconnecting battery cables. Using an insulated wrench, disconnect the negative (-) cable first and reconnect it last.

Check the battery terminals for clean, tight connections. Loose or corroded connections have high electrical resistance which makes starting harder.

3.2.3 Oil Level

⚠ WARNING

Engine components (drains, filters, hoses, etc.) can be hot and cause severe burns, lacerations of the skin, and liquid splash. Use personal protective equipment when working with or around hazardous materials. Examples of personal protective equipment include (but are not limited to) safety glasses, protective gloves, hard hats, steel toed boots, and protective clothing.

⚠ WARNING

Crankcase pressure can blow hot engine oil out the fill opening causing, severe burns. Always stop the generator set before removing the oil fill cap.

⚠ WARNING

State and federal agencies have determined that contact with used engine oil can cause cancer or reproductive toxicity. Avoid skin contact and breathing of vapors. Use rubber gloves and wash exposed skin.

⚠ CAUTION

Too little oil can cause severe engine damage. Too much oil can cause high oil consumption. Keep the oil level between the high and low beads (or markings) on the dipstick.

1. Shut off the generator set.
2. Pull the oil fill plug and dipstick out of the oil fill neck. The plug may be difficult to pull straight out - tilt the plug in its socket while pulling out.
3. Wipe off the dipstick and thread it back into the fill neck. Seat the plug, which snaps into its socket.
4. Remove the plug and dipstick again and check the oil level on the dipstick. Replace and seat the oil fill plug.
5. Add or drain oil as necessary if the oil level is not within the bead markings (FULL or ADD markings). See [Section 3.4 on page 26](#) for oil recommendations.

NOTICE

It is not necessary to add oil between oil changes unless the oil level has dropped more than 1/3 of the way between the high and low beads. A full quart (0.9 liter) can be added if the oil level is at the lower bead.

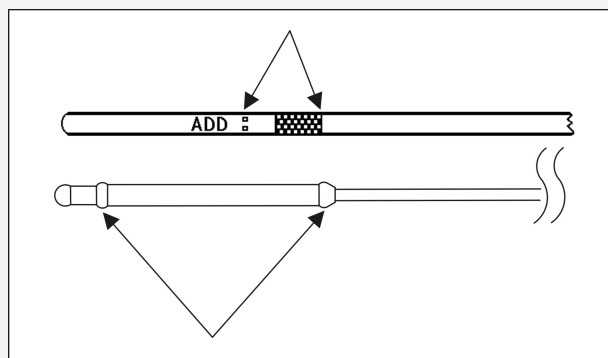

FIGURE 6. OIL LEVEL DIPSTICK ADD/FULL MARKINGS

3.2.4 Fuel System Leaks

⚠ WARNING

Fuel leaks can lead to fire. Repair leaks immediately. Do not run the generator set if it causes fuel to leak.

⚠ WARNING

1. Check for leaks at hose, tube, and pipe fittings in the fuel supply and return systems while the generator set is running and while it is stopped.
2. Check flexible fuel hoses for cuts, cracks, abrasions, and loose hose clamps.
3. Make sure fuel lines do not rub against other parts.
4. Replace worn or damaged fuel line parts before leaks occur. Replace hose with a high pressure fuel injection system USCG TYPE A1 or ISO 7840-A1 fuel hose.
5. Prime the fuel system if the generator set ran out of fuel.

3.2.5 Coolant Level

The recovery tank is designed to maintain coolant level, not to fill the system. Keep the level of coolant in the recovery tank between **COLD** and **HOT**. See [Section 3.6.6 on page 35](#) for coolant specifications. Also see [Section 3.6.8 on page 36](#) for detailed instructions on refilling the cooling system.

1. Check coolant level in the recovery tank and, if necessary, refill the recovery tank to **COLD** when the engine is cold or to **HOT** when it is at normal running temperature. Use the recommended antifreeze mixture.
2. If the tank is empty, check for and repair any coolant leaks and refill the system through the fill neck on the engine. Use the recommended antifreeze mixture.

3.2.6 Raw Water System

1. Clean out the sea water strainer, if necessary.
2. Make sure the sea-cock is open for generator set operation.
3. When a water/exhaust separator is provided, open the sea-cock for the water drain hose.
4. Check for hoses that leak or are damaged. Have a qualified service person replace any leaking or damaged hoses.

3.2.7 Exhaust System

⚠ WARNING

Exhaust gas is deadly. Do not operate the generator set until all exhaust leaks have been repaired.

1. Check that all CO monitors are working properly.
2. Inspect the exhaust system for leaks and loose hose clamps on:
 - exhaust manifold
 - exhaust elbow
 - muffler
 - water separator
 - hull fittings
3. Replace any damaged sections of exhaust hose.

3.2.8 Mechanical System

1. Monitor generator set status using the digital display.
2. Visually check the generator set for mechanical damage.
3. For generator sets with sound shield, install service doors before running the generator set, then listen for unusual noises when the generator set is running.
4. Check the generator set mounting bolts.
5. Check to see that the generator set air inlet and outlet openings are not clogged with debris or blocked.
6. Keep the generator set compartment clean.

3.3 Maintaining the Battery

WARNING

Flames, sparks, or arcing at battery terminals, light switches, or other equipment can ignite battery gas, causing severe personal injury. Ventilate the battery area before working on or near a battery, wear safety glasses, and do not smoke. Turn work light on or off away from the battery. When performing maintenance procedures or when servicing a battery, stop the generator set and disconnect the charger before disconnecting battery cables. Using an insulated wrench, disconnect the negative (-) cable first and reconnect it last.

Refer to [Section 3.1 on page 21](#) for the battery maintenance schedule and follow the battery manufacturer's instructions. Have the battery charging system serviced if DC system voltage is consistently low or high.

Check the battery terminals for clean, tight connections. Loose or corroded connections have high electrical resistance which makes starting harder.

1. Keep the battery case and terminals clean and dry.
2. Keep the battery terminals tight.
3. Remove battery cables with a battery terminal puller.
4. Make sure which terminal is positive (+) and which is negative (-) before making battery connections, always removing the negative (-) cable first and reconnecting it last to reduce arcing.

3.4 Maintaining the Lubrication System

Keep dirt, water, and other contaminants from entering the lubrication system and corroding or clogging lubrication components.

3.4.1 Oil Recommendations

CAUTION

Using normally specified CH-4 or equivalent oils will not allow a new or rebuilt engine to break-in properly.

⚠ CAUTION

- Use API (American Petroleum Institute) Service Category CH-4 engine oil or better after the first 100 hours of engine break-in.
- Look for the SAE (Society of Automotive Engineers) viscosity grade. Choose the viscosity grade appropriate for the ambient temperatures expected until the next scheduled oil change. See figure below.
- Multi-grade oils such as SAE 15W-40 are recommended for year-round use.

3.4.1.1 Oil Viscosity vs. Ambient Temperature

FIGURE 7. OIL VISCOSITY VS. AMBIENT TEMPERATURE

3.4.2 Changing Engine Oil and Filter**⚠ WARNING**

Accidental or remote starting can cause severe personal injury or death. Before removing a panel or access door, or before working on the generator set, use an insulated wrench to disconnect the negative (-) cable from the battery to prevent accidental starting.

⚠ WARNING

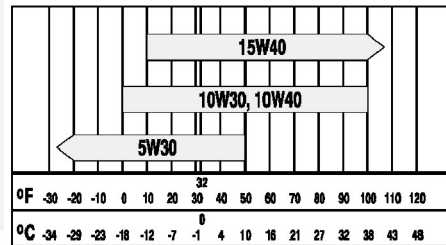
Engine components (drains, filters, hoses, etc.) can be hot and cause severe burns, lacerations of the skin, and liquid splash. Use personal protective equipment when working with or around hazardous materials. Examples of personal protective equipment include (but are not limited to) safety glasses, protective gloves, hard hats, steel toed boots, and protective clothing.

⚠ WARNING

State and federal agencies have determined that contact with used engine oil can cause cancer or reproductive toxicity. Avoid skin contact and breathing of vapors. Use rubber gloves and wash exposed skin.

Refer to [Chapter 3 on page 21](#) for the engine oil change schedule.

1. Run the generator set under load until it is up to operating temperature, stop it, and disconnect the negative (-) battery cable at the battery.
2. For generator sets with sound shield, remove service door.
3. Remove oil fill plug and open the drain valve. The drain valve has a 3/8 NPT outlet for connecting a hose fitting to facilitate oil drainage.

⚠ WARNING

Crankcase pressure can blow hot engine oil out the fill opening causing, severe burns. Always stop the generator set before removing the oil fill cap.

NOTICE

If an oil pump-out system is installed, follow the instructions provided with the pump.

NOTICE

Dispose of oil in accordance with local requirements.

4. Drain used oil into a suitable container.
5. Close the oil drain valve.
6. Remove the old oil filter or filters using a suitable filter wrench (available from Cummins Onan) and appropriately discard the filter or filters.
7. Remove the old gasket if it does not come off with the filter. Wipe the sealing surface clean.
8. Apply a film of oil to the new filter gasket and partly fill the new filter with oil so that it reaches engine parts sooner at startup.
9. Spin the filter on by hand until the gasket just touches the mounting pad and tighten 3/4 of a turn.
10. Refill the engine with the proper type and amount of engine oil. See previous section for oil recommendations and [Chapter 9 on page 105](#) for oil capacity.

⚠ CAUTION

Too little oil can cause severe engine damage. Too much oil can cause high oil consumption. Keep the oil level between the high and low beads (or markings) on the dipstick.

NOTICE

Do not fill the oil through the oil check port (where the dipstick is located) as oil will backup in the tube.

11. Check the oil level and add or drain oil as necessary.
12. Reinstall service doors on generator sets that have a sound shield.
13. Reconnect the negative battery cable.
14. Run the generator for a few minutes, shut it down, and recheck for proper oil level and leaks.
15. Dispose of the used oil and oil filter in accordance with local environmental regulations.

3.5 Maintaining the Fuel System

Keep dirt, water, and other contaminants from entering the fuel system and corroding or clogging fuel system components.

3.5.1 Fuel Recommendations

⚠ WARNING

Diesel fuel is combustible and can cause severe personal injury or death. Do not smoke near fuel tanks or fuel-burning equipment or in areas sharing ventilation with such equipment. Keep flames, sparks, pilot flames, electrical arcs and switches, and all other sources of ignition well away. Keep a multiclass fire extinguisher handy.

High quality Grade 2-D diesel fuel is necessary for good performance and long engine life. Use Grade 1-D diesel fuel where ambient temperatures are below 5 °C (40 °F). Where fuel is exposed to cold ambient temperature, use fuel that has a cloud point (temperature at which wax crystals begin to form) at least 6 Celsius (10 Fahrenheit) degrees below the lowest expected fuel temperature.

- Diesel fuels specified by EN 590 or ASTM D975 are recommended.
- The Cetane number should not be less than 45 and sulfur content not more than 0.5% by weight.
- The specifications for the type and sulfur content (ppm, % weight) of the diesel fuel used must comply with all emissions regulations applicable where the generator set is to be operated.
- Diesel fuel must meet the ASTM D975 standard for lubricity and pass a minimum load level of 3100 grams as measured by ASTM D6078, or maximum scar diameter of 0.45 mm as measured by ASTM D6079 or ISO 12156-1.
- B5 bio-diesel fuel that meets industry specifications and quality is suitable for use with this generator set.

3.5.2 Draining the Fuel Filter

The generator set may have a water-separator fuel filter. Check for other up-stream filters which may also need to be drained or replaced. Drain water and sediment more often than scheduled if fuel quality is poor, condensation cannot be avoided, or when a warning is being displayed for **WATER IN FUEL**.

Have towels and containers ready to clean, collect, and properly dispose of spilled or dripping fuel.

1. Using an insulated wrench, disconnect the negative (–) cable at the battery to prevent the engine from starting.
2. Open the front access door.
3. Remove drain plug on bottom of filter to drain water and sediment into a suitable container, about 120 ml (1/2 cup).
4. Re-install drain plug.
5. Replace the front access door.
6. Connect negative (–) battery cable.

7. Dispose of the drain-off in accordance with local environmental regulations.

3.5.3 Replacing Fuel Filter

⚠ WARNING

Accidental or remote starting can cause severe personal injury or death. Before removing a panel or access door, or before working on the generator set, use an insulated wrench to disconnect the negative (-) cable from the battery to prevent accidental starting.

⚠ WARNING

Engine components (drains, filters, hoses, etc.) can be hot and cause severe burns, lacerations of the skin, and liquid splash. Use personal protective equipment when working with or around hazardous materials. Examples of personal protective equipment include (but are not limited to) safety glasses, protective gloves, hard hats, steel toed boots, and protective clothing.

⚠ WARNING

Diesel fuel is combustible and can cause severe personal injury or death. Do not smoke near fuel tanks or fuel-burning equipment or in areas sharing ventilation with such equipment. Keep flames, sparks, pilot flames, electrical arcs and switches, and all other sources of ignition well away. Keep a multiclass fire extinguisher handy.

See [Section 3.1 on page 21](#) for scheduled fuel filter replacement. Replace the fuel filters if the engine lacks power. The generator set may have a primary and a secondary fuel filter. The primary filter has a water separator and sensor. Check for up-stream filters which may also need to be replaced.

1. Using an insulated wrench, disconnect the negative (-) cable at the battery to prevent the engine from starting.
2. Open the front access door (if applicable).
3. Close any fuel supply and return valves.
4. Spin off the old filter with a filter wrench.
5. Dispose of old filter in accordance with local environmental regulations.
6. Clean the contact surface on the filter base, lubricate the new filter gasket, and hand tighten the new filter.
7. Open any fuel supply and return valves.
8. Close the front access door, if applicable.
9. Prime the engine for at least 30 seconds to fill the new filter. Check for leaks as the generator set runs for several minutes.
10. Retighten the filter by hand, if necessary.
11. Connect the negative (-) cable at the battery.

3.5.4 Priming the Fuel System

⚠ WARNING

Diesel fuel is combustible and can cause severe personal injury or death. Do not smoke near fuel tanks or fuel-burning equipment or in areas sharing ventilation with such equipment. Keep flames, sparks, pilot flames, electrical arcs and switches, and all other sources of ignition well away. Keep a multiclass fire extinguisher handy.

⚠ WARNING

Engine components (drains, filters, hoses, etc.) can be hot and cause severe burns, lacerations of the skin, and liquid splash. Use personal protective equipment when working with or around hazardous materials. Examples of personal protective equipment include (but are not limited to) safety glasses, protective gloves, hard hats, steel toed boots, and protective clothing.

The fuel system should be primed after fuel filters are replaced or after the generator set runs out of fuel.

Push and hold **STOP (prime)** on the control switch or push and hold **STOP (prime)** on the digital display for at least 30 seconds. The **Generator** status lamp will blink while priming and the status on the digital display will change from **Stopped** to **Priming**.

3.6 Maintaining the Cooling System

The engine is cooled by a pressurized, closed-loop liquid system. Coolant is pumped through passages in the engine block, head, and exhaust manifold. The exhaust manifold also serves as the engine coolant reservoir.

Raw water (flotation water) is pumped through tubes in the heat exchanger to cool the engine coolant. The raw water then passes through a hose into the exhaust-water mixer where it cools the exhaust gases and is expelled.

3.6.1 Cooling System

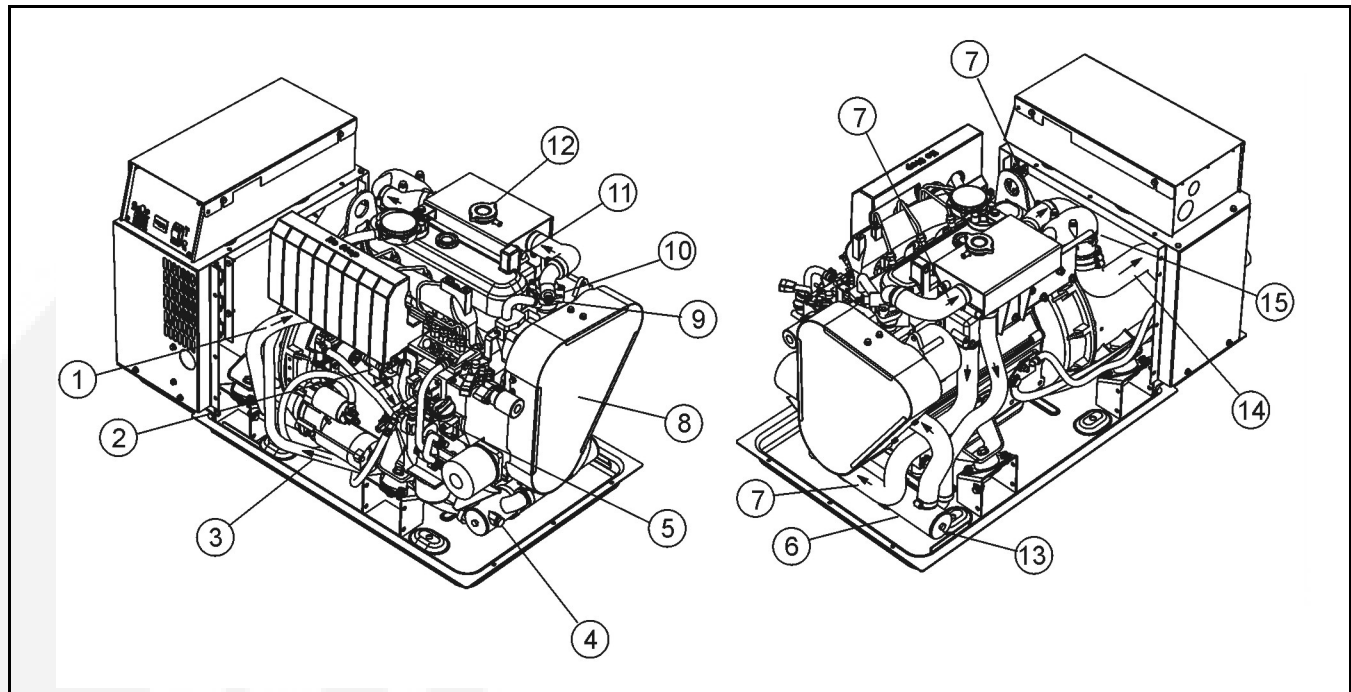

No.	Description	No.	Description
1	Raw Water to Pump from Bulkhead Fitting on Right or Left Side	9	Coolant Temperature Sensor
2	Raw Water Pump	10	Coolant Thermostat Housing
3	Raw Water Hose to Exhaust-Water Mixer - When required, replace with siphon break and connecting hoses	11	Location, Optional Low Coolant Sensor
4	Heat Exchanger with Zinc Anode and Clean Out Covers (both ends)	12	Coolant Reservoir with Pressure Cap and Coolant Fill Neck - Fill Neck has Hose Barb for Connecting Coolant Recovery Tank
5	Location, Block Drain Valve (Coolant)	13	Raw Water Cleanout Cover (Both Ends - Make Sure to Reconnect Ground Strap on This End with Cover Screw)
6	Coolant Drain Valve Raw Water Plugs (Underneath)	14	Exhaust and Raw Water Out to Bulkhead Fitting on Right or Left Side
7	Coolant Flow	15	Exhaust-Water Mixer with High Temperature Exhaust Switch
8	Coolant Pump Pulley		

FIGURE 8. MDKDP, MDKDR, AND MDKDV

3.6.2 Cooling System

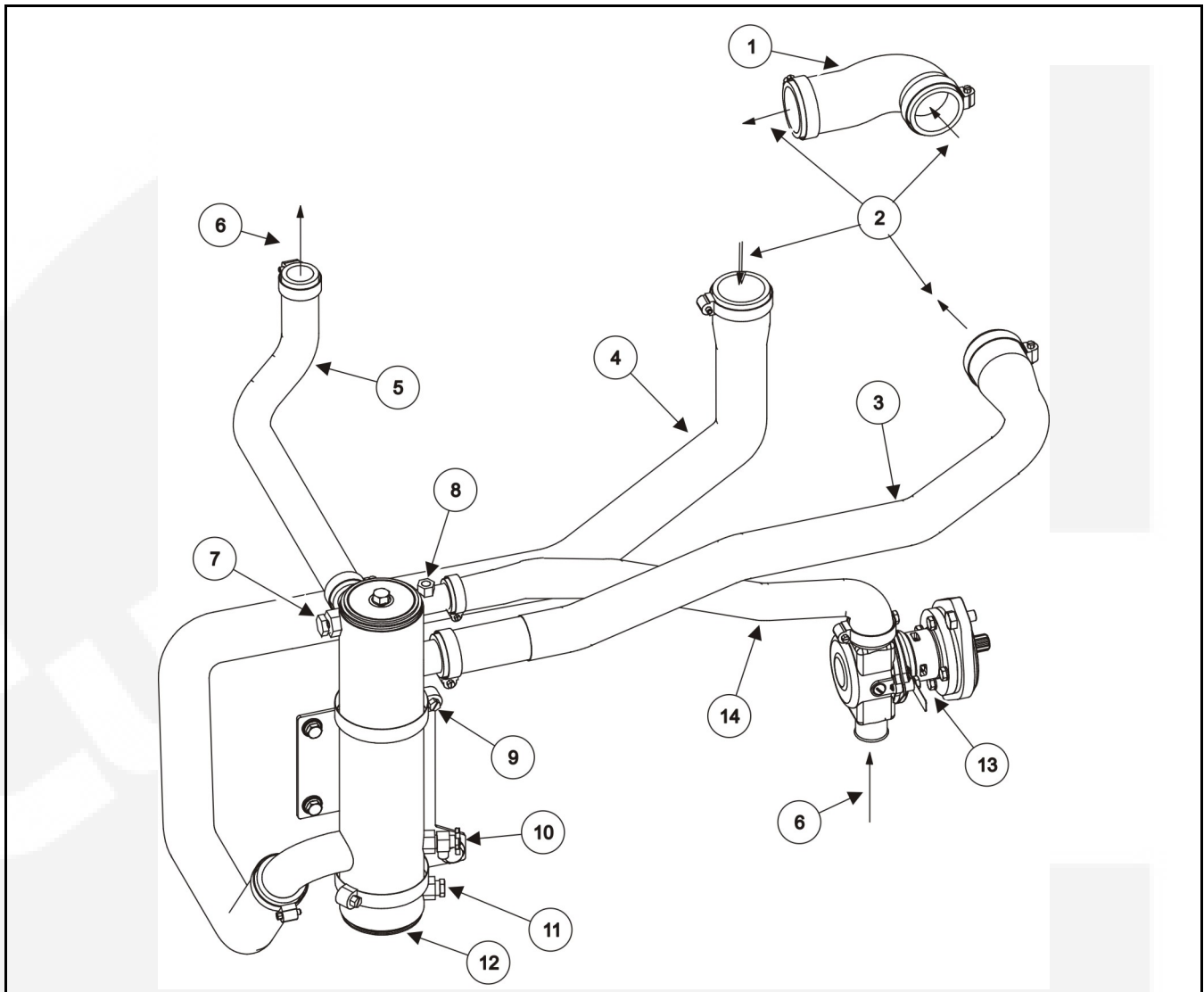

No.	Description	No.	Description
1	Hose, Thermostat to Coolant Reservoir	8	Raw Water Flow Switch
2	Coolant Flow	9	Heat Exchanger Mounting Straps (2) Torque to 11 Nm (8 ft-lb)
3	Hose, Heat Exchanger to Coolant Pump	10	Coolant Drain Valve
4	Hose, Coolant Reservoir to Heat Exchanger	11	Raw Water Drain Plug
5	Hose, Raw Water to Exhaust-Water Mixer - Replace hose with siphon break and connecting hoses when required - For dry exhaust replace with hose to hull fitting.	12	Heat Exchanger with Cleanout Covers (both ends)
6	Raw Water Flow	13	Raw Water Pump
7	Zinc Anode	14	Hose, Raw Water Pump to Heat Exchanger

FIGURE 9. MDKDS, MDKDT AND MDKDU

3.6.3 Pressure Cap

⚠ WARNING

Hot Coolant

Hot coolant is under pressure and can spray, causing severe burns when loosening the pressure cap or opening the coolant drain.

Let the engine cool before loosening the pressure cap. Wear safety glasses.

Replace the pressure cap every two years (seals deteriorate and leak). Proper cooling system pressure (7 psi) is essential for optimal engine cooling and minimal coolant loss.

3.6.4 Coolant Hoses

Check for and replace hoses that leak or are damaged.

Make sure the two hoses from the recovery tank are routed through the two holes in the right side of the generator set enclosure (if applicable), that the coolant recovery hose is connected to the fill neck on the engine, and that the overflow hose terminates in the drip pan where it will not splash coolant on electrical components.

3.6.5 Siphon Break

⚠ WARNING

Bypassing a siphon break or failing to maintain it can lead to engine flooding and damage to the engine that is not covered under warranty.

A siphon break is installed when the exhaust-water mixer is less than 6 inches above the water line. Replace the siphon break if it is encrusted with deposits, which indicates leakage. If it is of the bleed-vent type, check that the vent hose is connected to a through-hull fitting. Check for normal water flow whenever the engine is running. See the Installation Manual for more information regarding siphon breaks.

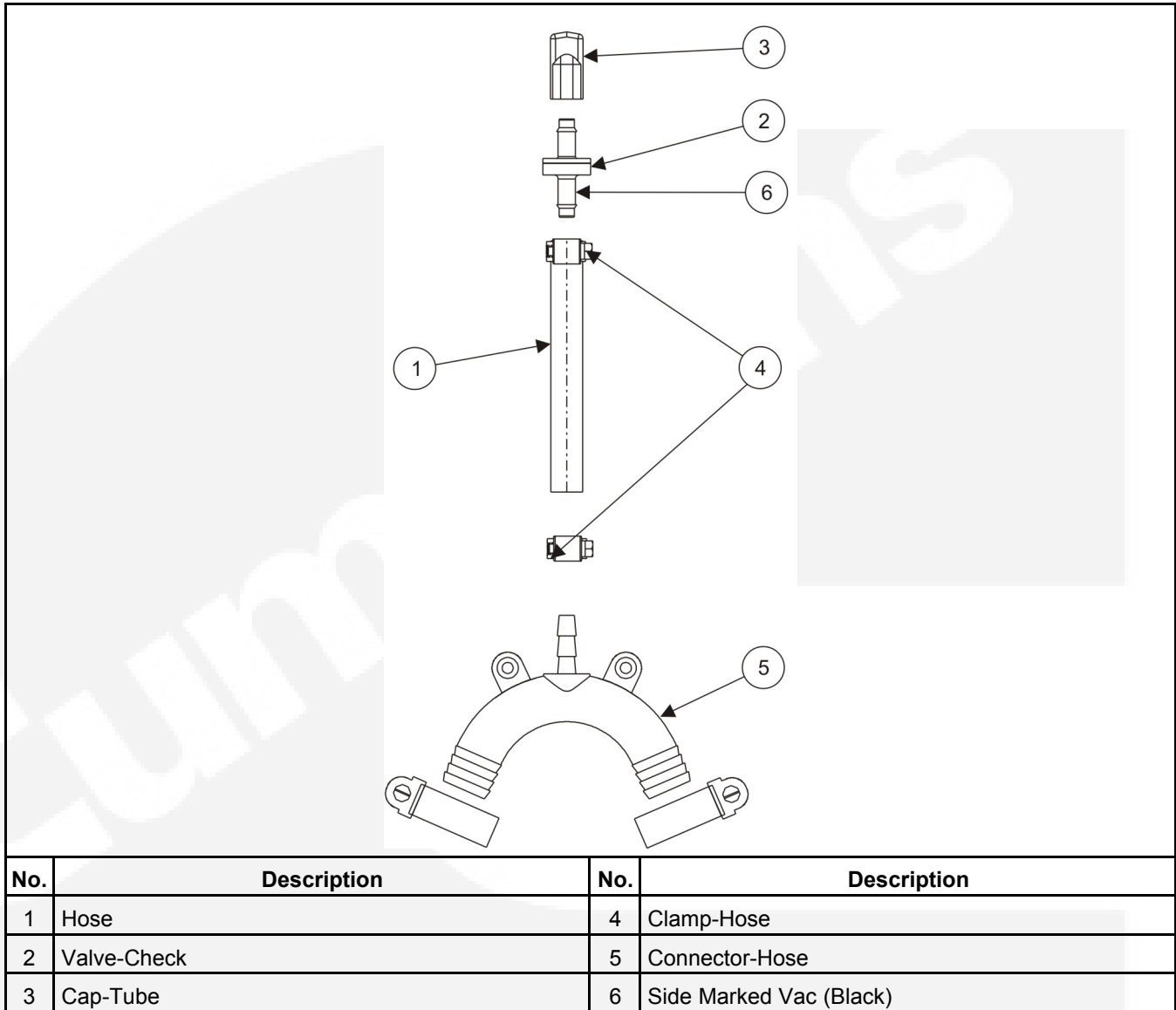

FIGURE 10. SIPHON BREAK

3.6.6 Coolant Recommendations

Use a high quality, fully formulated, ethylene glycol coolant with rust inhibitors and coolant stabilizers that meets ASTM D6210 Standard Specification for Fully-Formulated Glycol Base Engine Coolant for Heavy-Duty Engines. This will provide corrosion protection, foam control, liner-pitting protection, and scale/deposit control.

Unless prohibited by shipping regulations, the generator set is shipped with the recommended 50/50 mixture of water and ethylene glycol which provides protection to -37 °C (-34 °F). In warmer climates and sea water environments, a 60/40 mixture of water/ethylene glycol is recommended.

Use fresh water that is low in minerals and corrosive chemicals for the coolant mixture. Distilled water is best.

See [Chapter 9 on page 105](#) regarding coolant capacity.

⚠ WARNING

Ethylene glycol antifreeze is considered toxic. Dispose of it according to local regulations for hazardous substances.

3.6.7 Replenishing Normal Coolant Loss

Check coolant level in the recovery tank before the first startup of each day and, if necessary, refill to COLD when the engine is cold or to HOT when it is running. The recovery tank is designed to maintain coolant level, not to fill the system. If the tank is empty, check for and repair any coolant leaks and refill the system through the fill neck on the engine.

Make sure the two hoses from the recovery tank are routed through the two holes in the right end of the generator set enclosure, that the coolant recovery hose is connected to the fill neck on the engine, and that the overflow hose terminates in the drip pan where it will not splash coolant on electrical components.

3.6.8 Refilling Cooling System

⚠ CAUTION

Filling a hot engine with cold water can cause cracks in the manifold, head, and block. Follow the manufacturer's instructions for cleaning and flushing.

See [Section 3.6.6 on page 35](#) for coolant specifications. See [Chapter 9 on page 105](#) for coolant capacity.

1. Close the block and heat exchanger drain valves (or check to be sure they are closed), reconnect the pump inlet hose (or check to be sure it is connected), and fill the system through the engine fill neck. The system will fill only as fast as the air can escape. Fill to the bottom of the fill neck.
2. Start and run the engine for a couple of minutes to dislodge air pockets then shut it down.
3. Check the coolant level, add as much coolant as necessary, and secure the pressure cap.
4. Refill the recovery tank up to the COLD mark.
5. On sets with an enclosure, secure the top and front access doors. and use an insulated wrench to reconnect the battery cables, negative [-] last, when done.

⚠ CAUTION

Low coolant level can cause severe engine damage. Be sure the system is full.

3.6.9 Draining and Cleaning Cooling System

⚠ WARNING

*Hot Coolant
Hot coolant is under pressure and can spray, causing severe burns when loosening the pressure cap or opening the coolant drain.
Let the engine cool before loosening the pressure cap. Wear safety glasses.*

⚠ WARNING

Engine components (drains, filters, hoses, etc.) can be hot and cause severe burns, lacerations of the skin, and liquid splash. Use personal protective equipment when working with or around hazardous materials. Examples of personal protective equipment include (but are not limited to) safety glasses, protective gloves, hard hats, steel toed boots, and protective clothing.

1. Have towels and containers ready to clean, collect and properly dispose of the coolant.
2. Use an insulated wrench to disconnect the negative (-) cable at the battery to prevent the engine from starting, let the engine cool, remove the front access door, top of the enclosure and coolant pressure cap.
3. Remove the pressure cap.
4. Remove heat exchanger drain plug. Disconnect and drain lower hoses. Open block drain valve. Drain the coolant into suitable containers for disposal in accordance with the local regulations for hazardous substances.
5. Drain or flush a keel cooler in accordance with the manufacturer's instructions.
6. Use radiator cleaning chemicals to clean and flush the cooling system before refilling with fresh coolant. Follow the cleaner manufacturer's instructions.

⚠ CAUTION

Filling a hot engine with cold water can cause cracks in the manifold, head, and block. Follow the manufacturer's instructions for cleaning and flushing.

3.6.10 Heat Exchanger

⚠ WARNING

Accidental or remote starting can cause severe personal injury or death. Before removing a panel or access door, or before working on the generator set, use an insulated wrench to disconnect the negative (-) cable from the battery to prevent accidental starting.

⚠ WARNING

Engine components (drains, filters, hoses, etc.) can be hot and cause severe burns, lacerations of the skin, and liquid splash. Use personal protective equipment when working with or around hazardous materials. Examples of personal protective equipment include (but are not limited to) safety glasses, protective gloves, hard hats, steel toed boots, and protective clothing.

⚠ WARNING

Ethylene glycol is considered toxic. Do not use it to protect the raw water passages in the heat exchanger from freezing. It will be expelled into the environment when the generator set is started.

See [Section 3.1 on page 21](#) for scheduled maintenance. Clean the raw water tubes if the engine keeps shutting down (Code No. 1) or the engine gauge or digital display indicates abnormally high engine temperatures. Drain the heat exchanger if there is a danger of freezing when the generator set is not running or is in storage. Freezing water can damage the raw water tubes in the heat exchanger. Engine coolant is protected from freezing, water is not.

3.6.10.1 Heat Exchanger

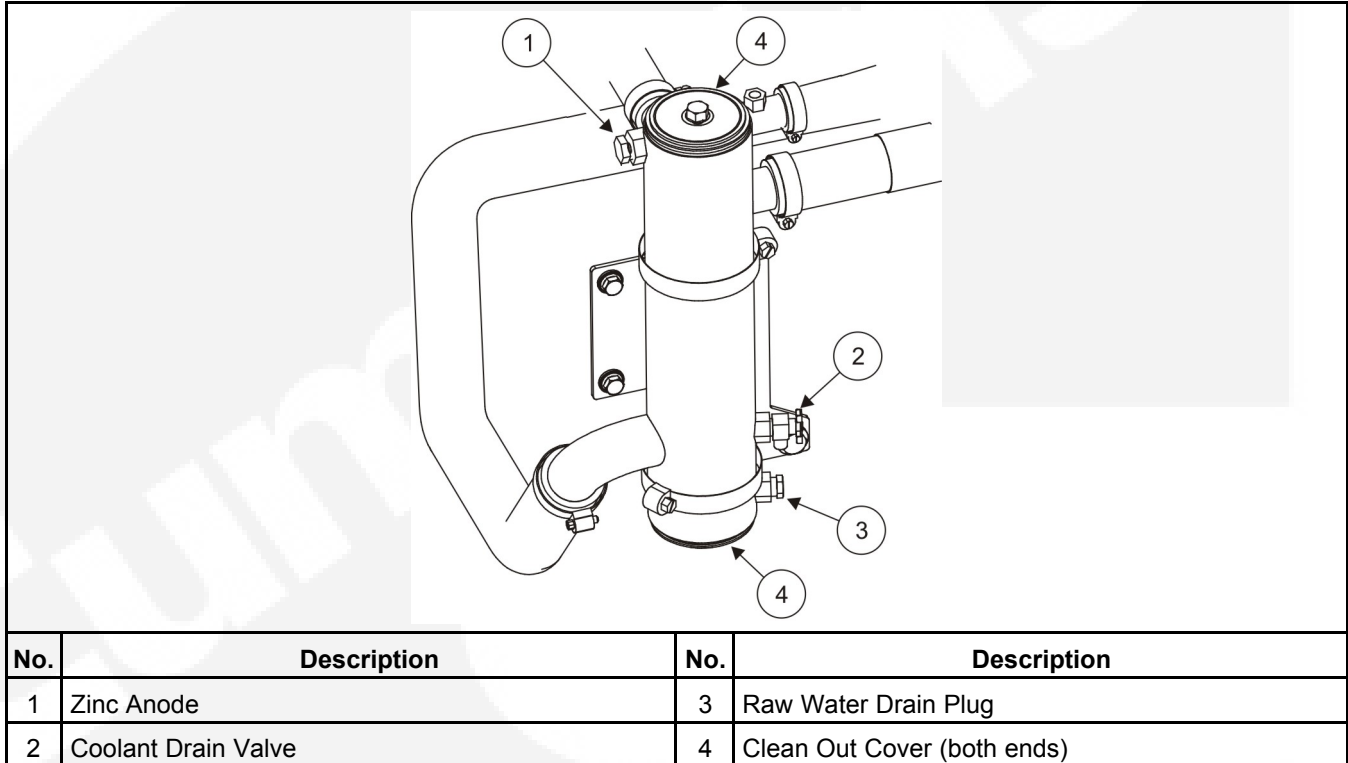

FIGURE 11. HEAT EXCHANGER

3.6.10.2 Removing and Installing the Heat Exchanger

Removal

1. Disconnect the four hoses. (To work the coolant hose elbow off the fitting on the heat exchanger, it will be necessary to loosen the hose clamps on both ends.)
2. Remove the screw and mounting straps.
3. Remove the heat exchanger.

Installation

1. Reconnect hoses.
2. Place heat exchanger in mounting bracket.
3. Install mounting strap and secure with screw.

3.6.10.3 Draining and Cleaning the Heat Exchanger

1. Disconnect the negative (-) cable at the battery to prevent the engine from starting, let the engine cool, and close the sea cock.

2. Remove the front access door, belt guard, top of the enclosure, and end panel, if so equipped.
3. Have towels and containers ready to prevent spilling raw water on the electrical components below the heat exchanger.
4. Remove the drain plug or clean-out cover.
5. Clean and flush the tubes. The drain plug must be removed to get all the water out of the tubes. Do not use metal rods to clean the tubes. The tubes are made of relatively soft copper alloy and can be easily damaged.

NOTICE

Have the heat exchanger cleaned at a radiator shop if there is hard scale in the tubes.

6. Use thread sealant on the drain plug and a new clean-out cover gasket if the old one is torn or otherwise damaged.
7. Reassemble all the parts that were disassembled for access.

3.6.11 Zinc Anode

Replace the zinc anode as recommended in [Chapter 3 on page 21](#). Use thread sealant on the zinc plug and drain plugs and replace the clean-out cover gaskets if the old ones are torn or otherwise damaged. See [Section 3.6.10 on page 37](#) for location of zinc anode.

3.6.12 Replacing the Thermostat

⚠ WARNING

Accidental or remote starting can cause severe personal injury or death. Before removing a panel or access door, or before working on the generator set, use an insulated wrench to disconnect the negative (-) cable from the battery to prevent accidental starting.

⚠ WARNING

Hot Coolant
Hot coolant is under pressure and can spray, causing severe burns when loosening the pressure cap or opening the coolant drain.
Let the engine cool before loosening the pressure cap. Wear safety glasses.

See the [Section 3.1 on page 21](#) section for scheduled replacement.

1. Use an insulated wrench to disconnect the negative battery cable at the battery to prevent the engine from starting. Let the engine cool and remove the front access door.
2. Remove the pressure cap.
3. Drain the cooling system following procedure in previous section - Draining and Cleaning the Cooling System.
4. Remove the two thermostat housing bolts and pull off the housing, thermostat, and gasket. The hose does not need to come off.

5. Clean off the gasket area and install the new thermostat and gasket. Apply Three Bond 1215 liquid sealant or equivalent to the top side of the gasket.
6. Replenish any lost coolant (refer to the previous section - Refilling the Cooling System), secure the pressure cap, secure the top of the enclosure and access door, and reconnect the negative battery cable.

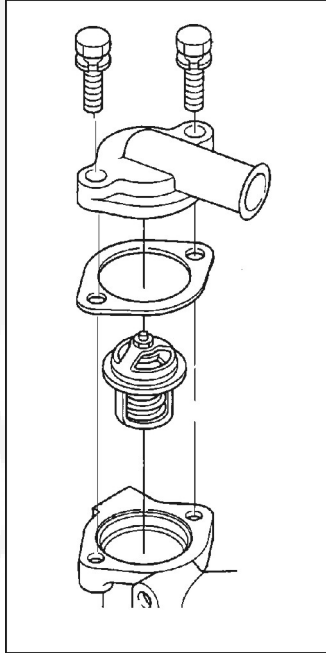

FIGURE 12. TYPICAL THERMOSTAT AND HOUSING

3.6.13 Replacing Raw Water Pump Impeller

⚠ WARNING

Accidental or remote starting can cause severe personal injury or death. Before removing a panel or access door, or before working on the generator set, use an insulated wrench to disconnect the negative (-) cable from the battery to prevent accidental starting.

⚠ WARNING

Engine components (drains, filters, hoses, etc.) can be hot and cause severe burns, lacerations of the skin, and liquid splash. Use personal protective equipment when working with or around hazardous materials. Examples of personal protective equipment include (but are not limited to) safety glasses, protective gloves, hard hats, steel toed boots, and protective clothing.

See [Section 3.1 on page 21](#) for scheduled replacement. Avoid spilling raw water on the electrical components below the pump. Have towels and containers ready in case of water spillage.

1. Close the sea-cock.
2. Disconnect the negative (-) cable at the battery to prevent the engine from starting.
3. Loosen the three screws on the end of the pump body to remove the pump body or impeller cover, depending on construction (see below).

4. Remove the impeller and O-ring. An impeller removal tool may be necessary to pull the impeller off the shaft.
5. Inspect impeller for broken vanes. Check for and clean out pieces that may have lodged in the heat exchanger.
6. Install the new impeller - for easier installation, twist the impeller the way it normally turns on its own while squeezing it into the housing.
7. To provide initial lubrication and better pump suction before water reaches the pump, wet the inside of the pump and impeller with water, soap solution, or a silicone lubricant and secure the O-ring and cover.

⚠ CAUTION

Do not lubricate with petroleum products like grease and oil which chemically attack impeller materials.

8. Secure the cover or pump body and O-ring.
9. If the sea water strainer is above the water line, fill it for faster priming at startup.
10. Open the sea-cock, reconnect the negative battery cable and start the generator set. The generator set will shut down within a few seconds if there is no raw water flow, and the amber status lamp will blink shutdown Code No. 7. If it shuts down, remove any blockage and restart the generator set.

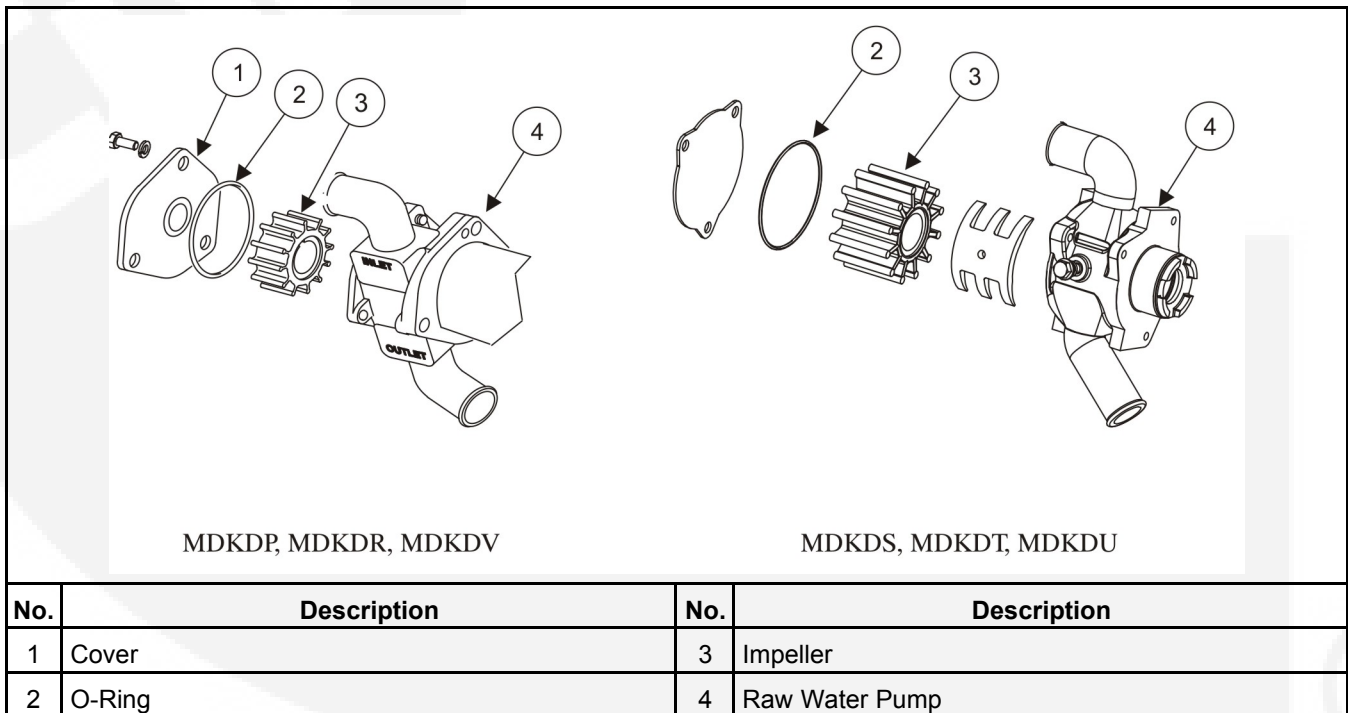

FIGURE 13. REPLACING THE RAW WATER PUMP IMPELLER

3.6.14 Adjusting V-Belt Tension

⚠ WARNING

Accidental or remote starting can cause severe personal injury or death. Before removing a panel or access door, or before working on the generator set, use an insulated wrench to disconnect the negative (-) cable from the battery to prevent accidental starting.

1. Use an insulated wrench to disconnect the negative (-) cable at the battery to prevent the engine from starting.
2. Remove the belt guard or enclosure top panel and access doors.
3. Loosen the alternator pivot bolt first and then the adjusting bracket bolt on top.
4. Pivot the alternator out to tighten belt tension. Hold tension by tightening the tension adjusting bolt and then check tension by applying 10 kg (20 pounds) to the middle of the pulley span. Belt tension is correct when deflection is 10 mm (3/8 inch).
5. Tighten the alternator bolts when tension is correct.
6. Tighten the bolts, secure the belt guard or enclosure and reconnect the negative battery cable.

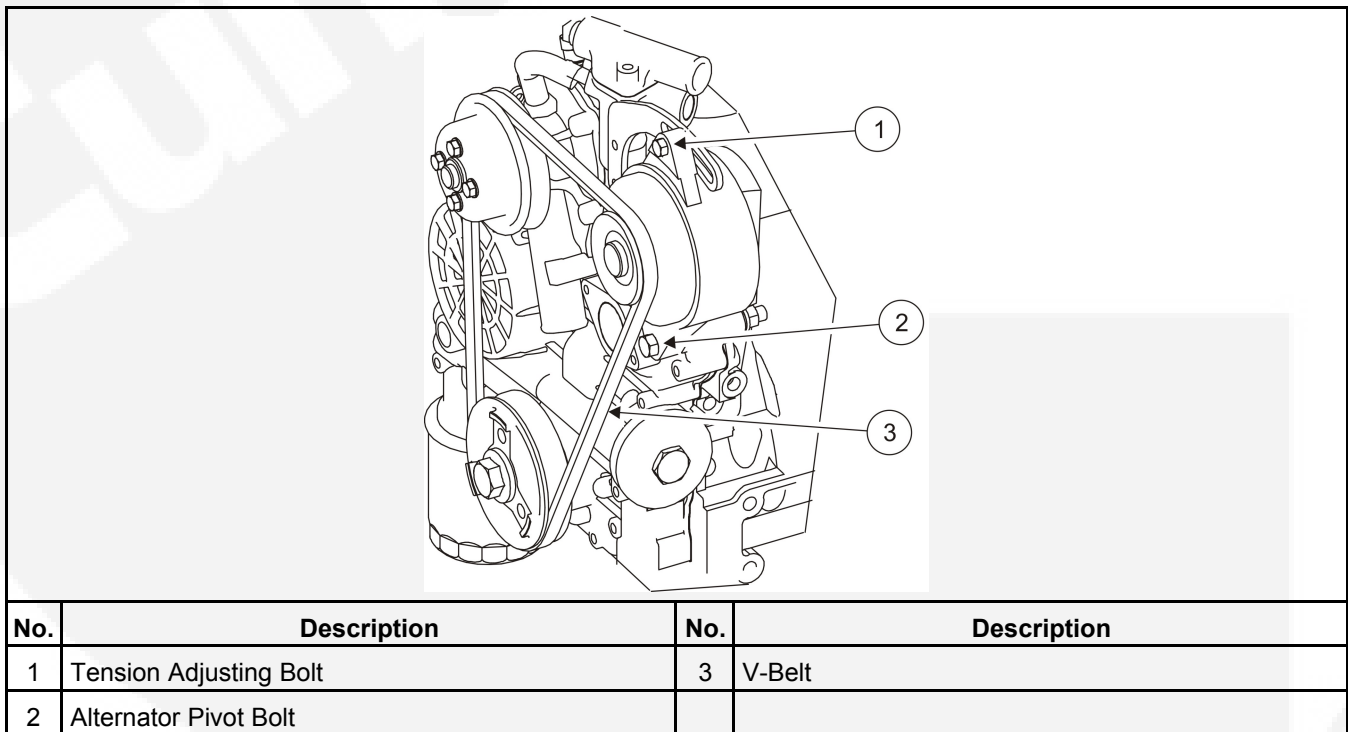

FIGURE 14. ADJUSTING V-BELT TENSION

3.6.15 Replacing V-Belt When PTO Equipped

A special belt replacement kit must be used when the generator set is equipped with a PTO. The kit includes a tool to keep the flexible coupling from twisting during assembly and disassembly. The coupling has to be disassembled so that the belt can be looped around the crank pulley. Follow the instructions in the kit.

3.7 Storing the Generator Set

When the generator set cannot be exercised regularly and (or) will be idle for more than 120 days, proper storage is essential in preserving top performance and reliability.

1. Turn off the generator set line circuit breaker or AC distribution panel.
2. Change the engine oil and filter and attach a tag indicating oil viscosity.
3. Crank the engine several revolutions by pressing the start switch momentarily but do not let it start. This will fill the oil passages with the new oil.
4. Use an insulated wrench to disconnect the battery cables, negative [-] cable first, from the starting battery and store the battery according to the battery manufacturer's recommendations. Check coolant level and add as necessary. Test the coolant mixture if freezing temperatures are possible and change if necessary.
5. Drain the heat exchanger and muffler if freezing temperatures are expected.
6. Disengage the PTO clutch, if so equipped.
7. Clean and lightly oil parts that can rust.

3.8 Cold Temperature Storage

Freezing water can damage the heat exchanger and exhaust cooler. Drain these of any water before freezing temperatures begin. See [Section 3.7 on page 43](#).

3.9 Returning the Generator Set to Service

1. Check the oil tag on the generator set and change the oil if the viscosity indicated is not appropriate for the temperatures expected.
2. Use an insulated wrench to reconnect the starting battery, negative [-] cable last.
3. Replace the raw water pump impeller if it is over one year old.
4. Reinstall the PTO clutch, if so equipped.
5. Perform required maintenance.
6. After connecting the battery complete the pre-start checks and prime the fuel system.
7. Start and run the generator set.
8. Turn on the generator set line circuit breaker or distribution panel when ready to power loads.



This page is intentionally blank.



4 Generator Set Control

4.1 Overview

WARNING

*Accidental or remote starting.
Accidental or remote starting of the generator set can cause severe personal injury or death.
Prevent accidental or remote starting by disconnecting the starting battery cables (negative [-] first), using an insulated wrench and isolating all auxiliary supplies.*

The control board has a microprocessor controller that provides all the control, monitoring, and diagnostic functions required to operate the generator set.

Up to three Cummins Onan Digital Displays may be connected to the generator set for operator control and monitoring.

An optional Network Interface Module (NIM) is available for mounting in the control box. It is equipped with a connector for external SAE J1939 data link connections to an integrated boat monitoring system.

Refer to [Appendix A on page 115](#) and [Appendix C on page 129](#) for more information on control board wiring and harnesses.

4.2 Controller

4.2.1 Major Functions of Generator Set Controller

4.2.1.1 Initialization

Control initialization consists of checking memory (RAM, ROM, EEPROM) and generator set configuration.

4.2.1.2 Fuel Prime

Press and hold the control switch at **STOP (Prime)** for more than 3 seconds to cause fuel pump (E5) to prime the fuel system.

4.2.1.3 Start

Press and hold the control switch at **START (Preheat)** until the generator set starts. The controller:

1. Enables the status lamp (amber) to blink rapidly.
2. Enables some fault detection.
3. Energizes fuel lift pump (E5).
4. Energizes the glow plugs during pre-heat and cranking. The duration of pre-heat prior to cranking is engine temperature dependent, but not to exceed 15 seconds.
5. Enables cranking. The maximum allowed duration of cranking is 20 to 60 seconds, depending on engine temperature.

6. Enables field flash if no frequency pulses are present (F1-F2).
7. Energizes governor actuator (A12) (full rack).
8. Disconnects the starter (B1) at 800 RPM.
9. When operating speed is reached:
 - a. Enables output voltage.
 - b. Turns off field flash.
 - c. Switches amber status lamp to green run lamp.
 - d. Enables Switched B+ (J7).
 - e. Enables complete fault detection.

4.2.1.4 Stop

Touch the control switch to **STOP (Prime)**. The controller:

1. Disables output voltage.
2. De-energizes the fuel lift pump and governor actuator.
3. Turns off the status lamp.
4. Writes session data (number of cranks, minutes of operation, last fault, etc.) to non-volatile memory (NVM).
5. Removes processor power when idle 5 minutes.

NOTICE

Stop takes precedence over Start if both are present due to a faulty switch or other cause.

4.2.1.5 Fuel Control

The controller positions the fuel rack to maintain nominal frequency as load varies by sending a pulse-width-modulated (PWM) square-wave signal to governor actuator A12. It determines frequency by sensing the frequency of the quadrature winding output. When the actuator is not energized, its spring-loaded plunger holds the fuel rack in the no-fuel position.

4.2.1.6 Voltage Control

The controller maintains nominal AC output voltage during steady state operation by varying field current as load varies. In response to transient loads it lowers the voltage set-point to allow engine recovery. Field power (DC) is supplied by the quadrature windings (Q1-Q2) (AC) through the controller.

4.2.1.7 Voltage Adjustment

See [Chapter 7 on page 87](#).

4.2.1.8 Fault Monitoring, Shutdown and Diagnostics

See the Troubleshooting Chapter of this manual ([Chapter 8 on page 91](#)).

4.2.2 Control Block Diagram

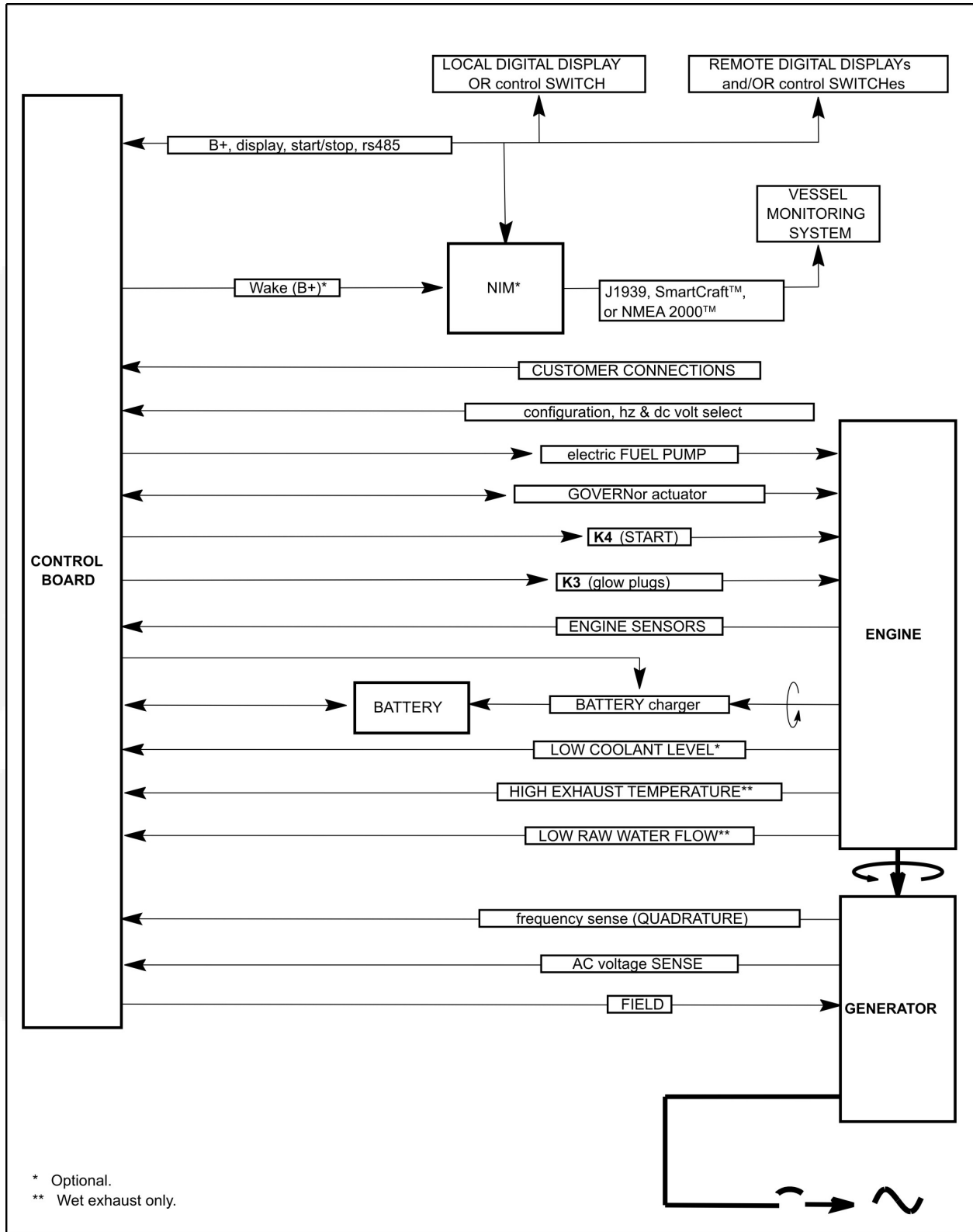

FIGURE 15. CONTROL BLOCK DIAGRAM

4.2.3 Connectors

All connections to the controller are through connectors P1/J1 (black), P2/J2 (gray) and P3/J3 (green). When removing a connector from the controller, squeeze the locking tabs on the sides while pulling out. When reinstalling a plug, make sure the seal is in place and that the locking tabs snap into position.

⚠ CAUTION

Makeshift meter test probes used for testing control board connections during troubleshooting can damage pin sockets by spreading or dislodging the contact wiper arms, resulting in an open or intermittent electrical connection. Use a mating pin (Cummins Onan PN 323-1491) or a test probe that is 0.045 inches in diameter. Replace damaged pin sockets (Cummins Onan PN 323-1492). Make sure the pin sockets are fully seated and cannot be pulled out.

4.2.4 Removal/Replacement

⚠ WARNING

Accidental or remote starting can cause severe personal injury or death. Before removing a panel or access door, or before working on the generator set, use an insulated wrench to disconnect the negative (-) cable from the battery to prevent accidental starting.

The control board is secured to the access cover by 2 screws. The cover is secured by 4 screws to the enclosure end panel. Remove the 4 cover screws and withdraw the control board with the cover. To remove the control board, first disconnect the 3 connectors (P1, P2 and P3) by squeezing the locking tabs on the sides of the connectors while pulling out.

When reinstalling a connector plug, make sure the seal is in place and that the locking tabs snap into position.

4.2.4.1 Generator Controller Mounting

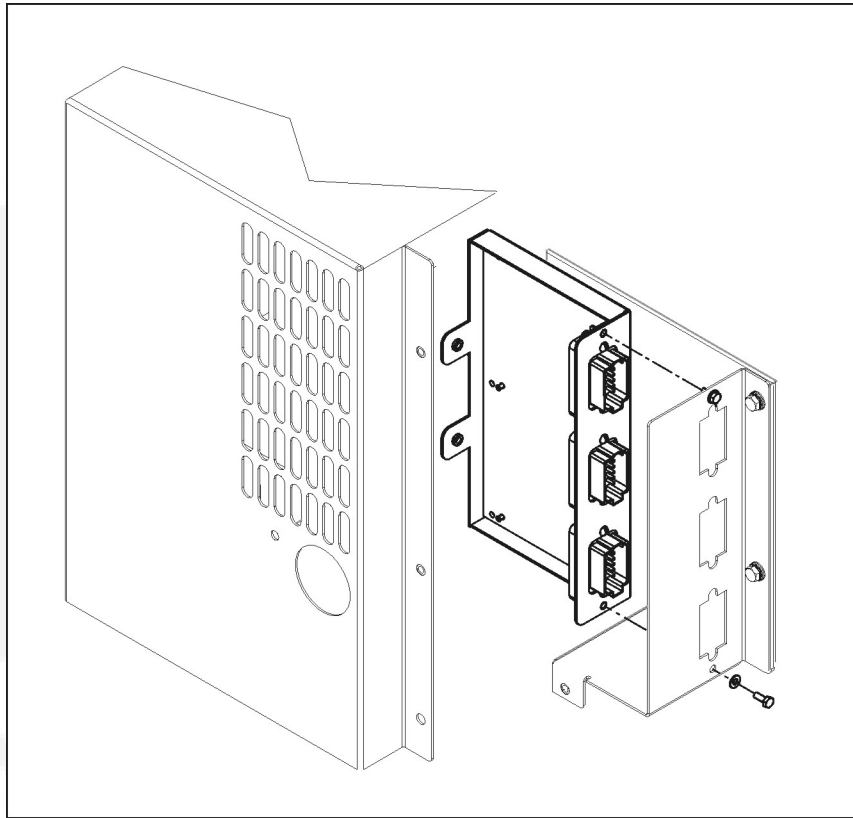

FIGURE 16. GENERATOR CONTROLLER MOUNTING

4.2.5 Configuring Generator Set Controller Using Digital Display

A replacement controller must be configured to the generator set configuration (1-phase or 3-phase). An INVALID GENSET CONFIGURATION - CODE NO.37 shutdown will occur at startup if not configured properly. Also, the digital display hour meter should be set to match the master hour meter.

Setting Configuration:

1. Stop the generator set and press STOP 6 times to display the configuration screen.
2. Press NEXT to select Genset Config.
3. Press the up-down arrows to select the configuration number marked on the generator set nameplate, or see table below.
4. Press BACK to save the selection and get back to GEN STATUS.

Setting Digital Display Hour Meter:

1. Press NEXT to select Set Hour Meter.
2. Press the up-down arrows to match the number or hours on the master hour meter.
3. Press BACK to save the selection and get back to GEN STATUS.

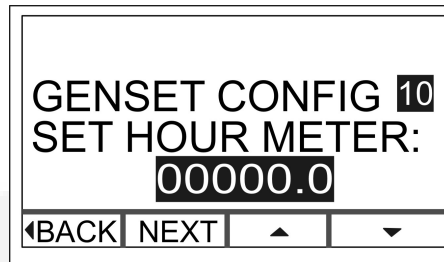

FIGURE 17. CONFIGURING CONTROLLER AND SETTING HOUR METER

4.2.5.1 Generator Set Configuration Codes

TABLE 2. GENERATOR SET CONFIGURATION CODES

Generator Set Model	Generator Set Phase	Frequency	Configuration
13.5 MDKDP	1 Ph	50 Hz	14
13.5 MDKDP	3 Ph	50 Hz	24
17.5 MDKDR	1 Ph	50 Hz	15
17.5 MDKDR	3 Ph	50 Hz	16
19 MDKDV	1 Ph	50 Hz	46
19 MDKDV	3 Ph	50 Hz	47
22.5 MDKDT	1 Ph	50 Hz	41
22.5 MDKDT	3 Ph	50 Hz	43
27 MDKDU	1 Ph	50 Hz	42
27 MDKDU	3 Ph	50 Hz	45
17 MDKDP	1 Ph	60 Hz	52
17 MDKDP	3 Ph	60 Hz	56
21.5 MDKDR	1 Ph	60 Hz	53
21.5 MDKDR	3 Ph	60 Hz	54
29 MDKDS	1 Ph	60 Hz	57
29 MDKDS	3 Ph	60 Hz	58

4.2.6 Configuring Generator Set Controller Using Control Switch

1. Remove the insulating connectors from wiring harness connectors CONFIG 1 and CONFIG 2 in the control box and connect them together. This places the control in configuration mode. (In configuration mode the control will not start, prime, or display faults.)
2. The status lamp on the control switch will blink the numeric configuration code, a two-digit number. See above table for appropriate code number.
3. Press START or STOP to increase or decrease the code number. For example, the lamp should blink as follows when configured for a 1-Phase, Model MDKDR generator set (15): blink — pause — blink-blink-blink-blink-blink — long pause — repeat code
4. When configured properly, disconnect CONFIG 1 from CONFIG 2 and re-install the insulating connectors that were removed from each connector.

4.3 Control Switch Schematic

The control switch, when located on the generator, is mounted on the control panel. Unsnap the connector for access to its terminals. See [Appendix A on page 115](#) for connections.

Referring to the figure below, replace the switch if:

- **START** does not close terminals 2 and 3,
- **STOP** does not close terminals 1 and 2,
- Green does not light when 12 VDC is applied across terminals 7 (-) and 8 (+),
- Amber does not light when 12 VDC is applied across terminals 7 (-) and 6 (+).

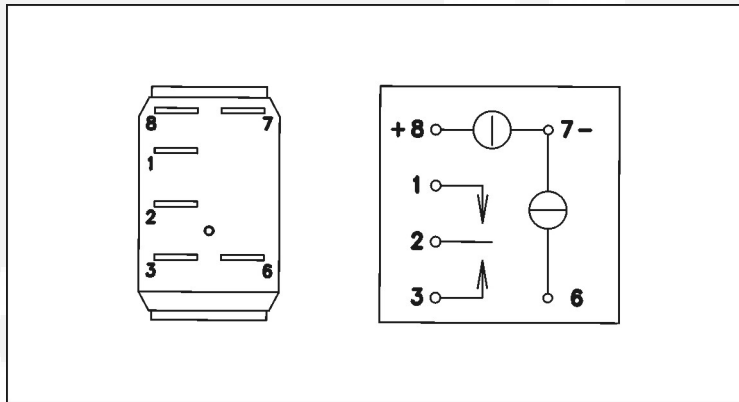

FIGURE 18. CONTROL SWITCH SCHEMATIC AND TERMINALS

4.4 Control Relays

To test a relay, apply 12 VDC (or 24 VDC if applicable) across terminals 85-86 (see figure below). Replace the relay if 30-86 (NO) does not close or 30-87a (NC) does not open, or either does not return to its normal position when power is removed.

See the drawings in [Appendix A on page 115](#) for relay function.

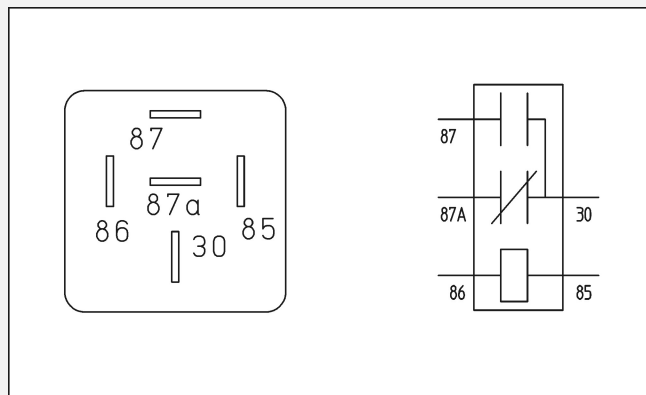

FIGURE 19. CONTROL RELAY TERMINALS AND SCHEMATIC

4.5 Master Hour Meter (M11)

See Operator Manual for instructions on how to reset the hour meter on the digital display to match the master hour meter when replacing the generator set controller.

4.5.1 Master Hour Meter (M11)

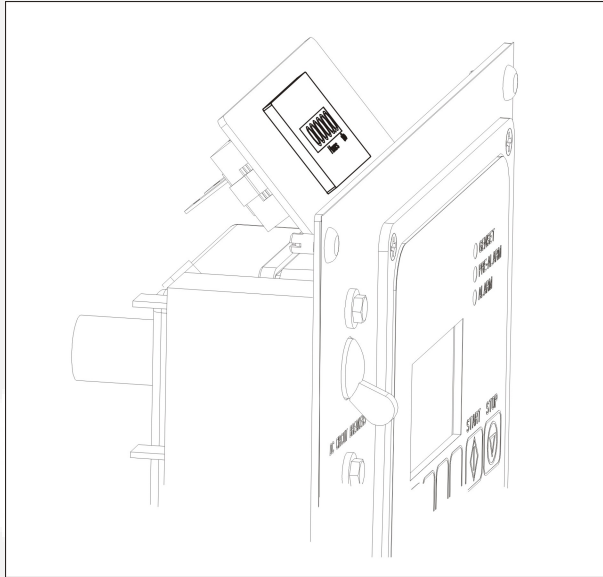

FIGURE 20. MASTER HOUR METER MOUNTED ON BRACKET

4.6 Emergency Stop Switch/Circuit Breaker

The switch/circuit breaker is mounted on the control panel. Disconnect the leads and check electrical continuity across the two terminals. Replace the circuit breaker if it does not reset, turn on, or turn off. For easier access to the switch terminals, push out the four plastic buttons that secure the panel and pull the panel with switch forward.

4.7 DC Circuit Breaker

The switch/circuit breaker is mounted on the control panel. Disconnect the leads and check electrical continuity across the two terminals. Replace the circuit breaker if it does not reset, turn on, or turn off. For easier access to the switch terminals, push out the four plastic buttons that secure the panel and pull the panel and switch forward.

4.8 Engine Oil Pressure Sensor (E1)

In isolated ground applications the sensor has two terminals. Use thread sealant and engage at least two full threads when installing. Replace the sensor if resistance is not between 227 and 257 ohms when the engine is stopped (0 psi). See [Appendix A on page 115](#) for connections.

4.8.1 Oil Pressure Sensor (E1)

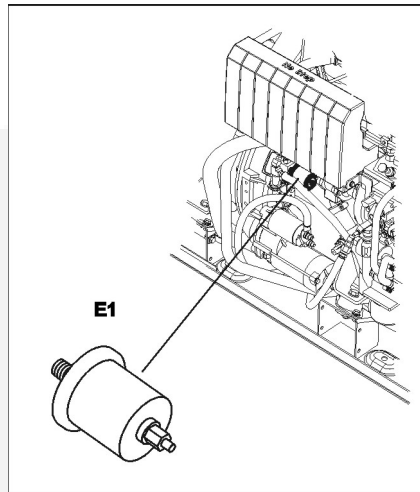

FIGURE 21. MDKDP, MDKDR, MDKDV

4.8.2 Oil Pressure Sensor (E1)

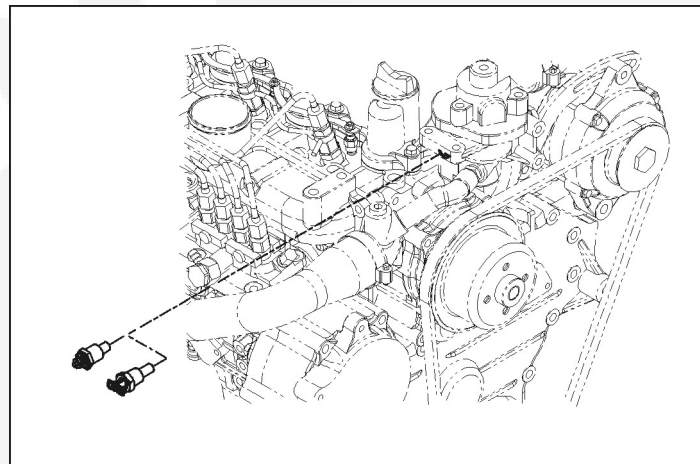

FIGURE 22. MDKDS, MDKDT, MDKDU

4.9 Coolant Temperature Sender (E2)

In isolated ground applications the sender has two terminals. Use thread sealant and engage at least two full threads when installing. Replace the sender if resistance is not approximately 800 ohms at room temperature or does not decrease rapidly when immersed in boiling water. See [Appendix A on page 115](#) for connections.

4.9.1 Coolant Temperature Sender (E2)

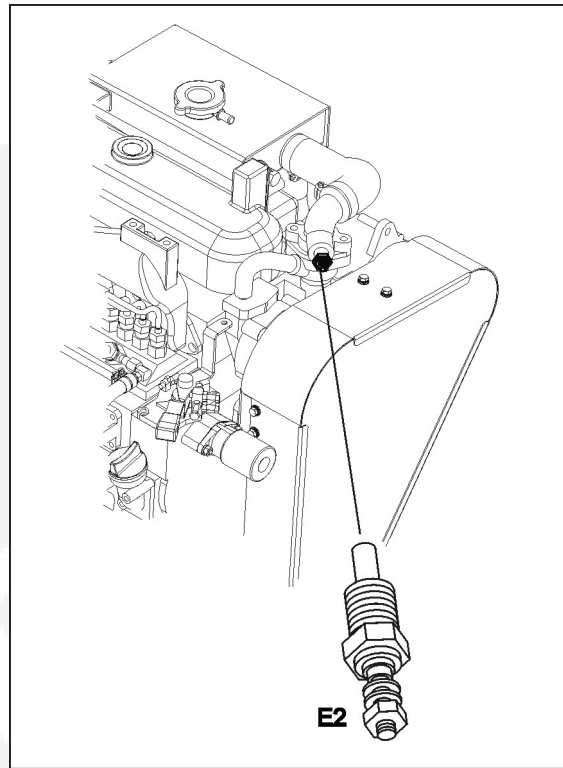

FIGURE 23. MDKDP, MDKDR, MDKDV

4.9.2 Coolant Temperature Sender (E2)

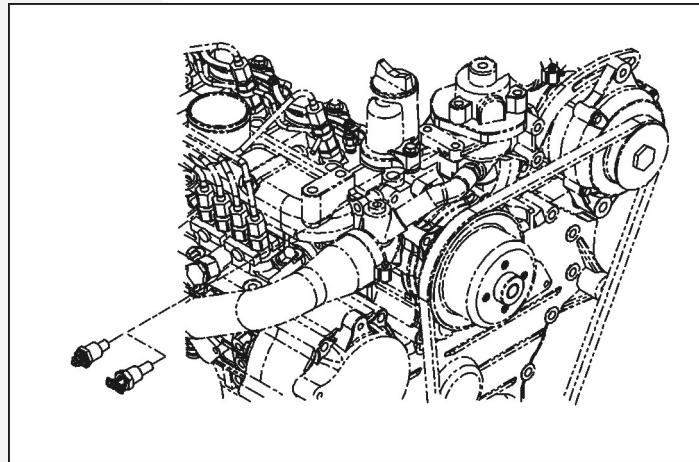

FIGURE 24. MDKDS, MDKDT, MDKDU

4.10 High Exhaust Temperature Switch (S5)

The high exhaust temperature switch is provided on models with wet exhaust and is a normally-closed switch. It is secured to the side of the water/exhaust mixer. See [Appendix A on page 115](#) for connections.

4.10.1 High Exhaust Temperature Switch (S5)

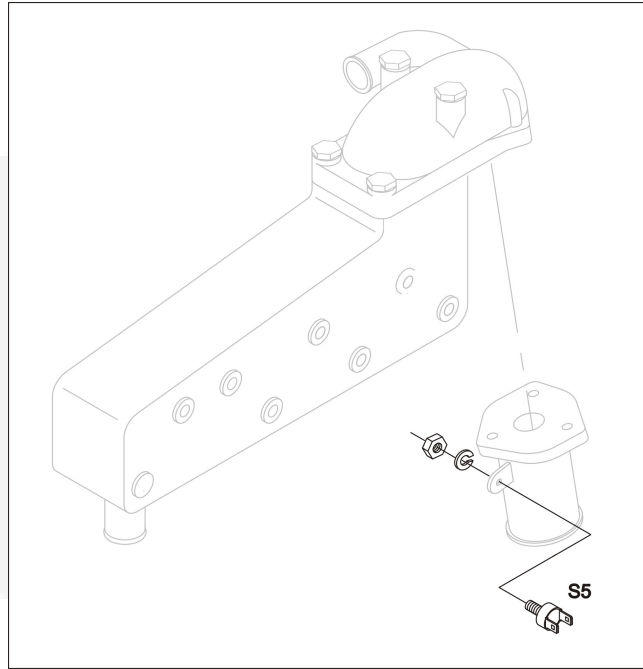

FIGURE 25. MDKDP, MDKDR, MDKDV

4.10.2 High Exhaust Temperature Switch (S5)

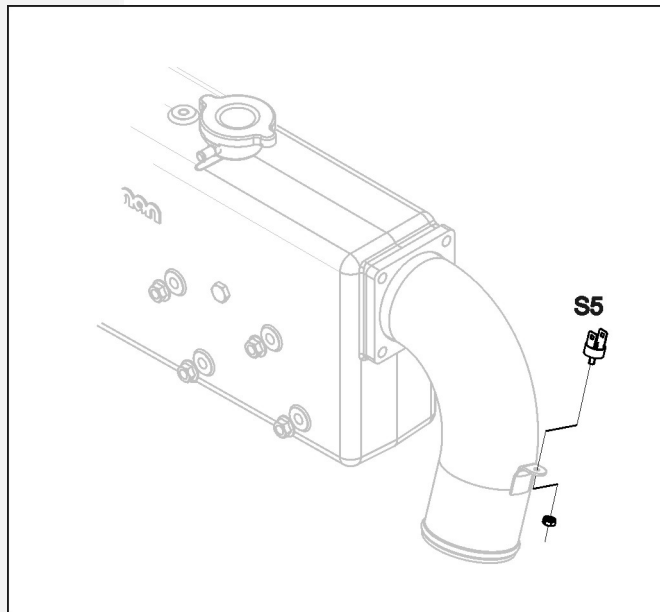

FIGURE 26. MDKDS, MDKDT, MDKDU

4.11 Raw Water Flow Switch (S6)

This switch is provided on models having a heat exchanger. The raw water flow switch is threaded into the heat exchanger. It is a normally-closed switch. Use thread sealant and engage at least two full threads when installing.

Check continuity across the switch terminals while blowing into it (1 psi). Replace the switch if it does not open and close.

See [Appendix A on page 115](#) for connections.

4.11.1 Raw Water Flow Switch (S6)

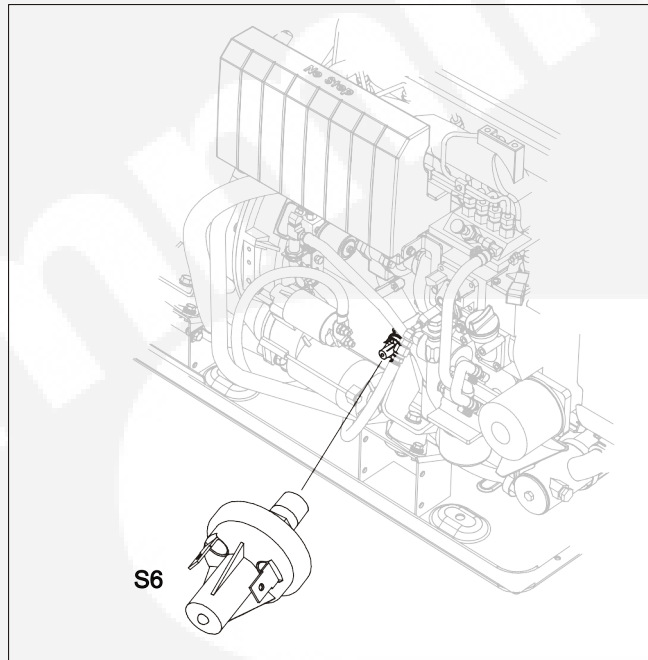

FIGURE 27. MDKDP, MDKDR, MDKDV

4.11.2 Raw Water Flow Switch (S6)

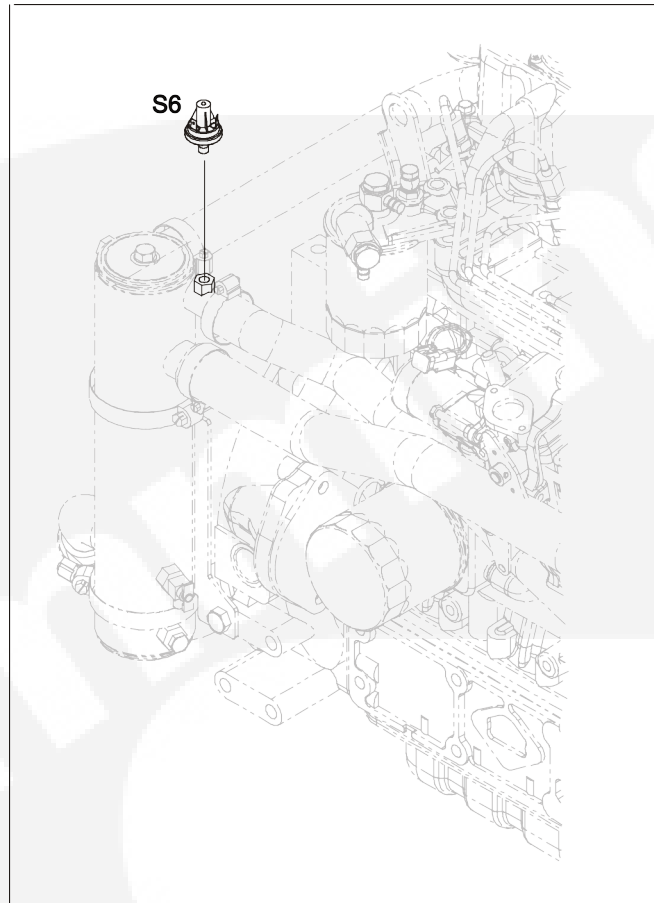

FIGURE 28. MDKDS, MDKDT, MDKDU

4.12 Low Coolant Level Switch (S3)

When provided, the low coolant level switch is threaded into the coolant reservoir. Use thread sealant and engage at least two full threads when installing. See [Appendix A on page 115](#) for connections.

4.12.1 Low Coolant Level Switch (S3)

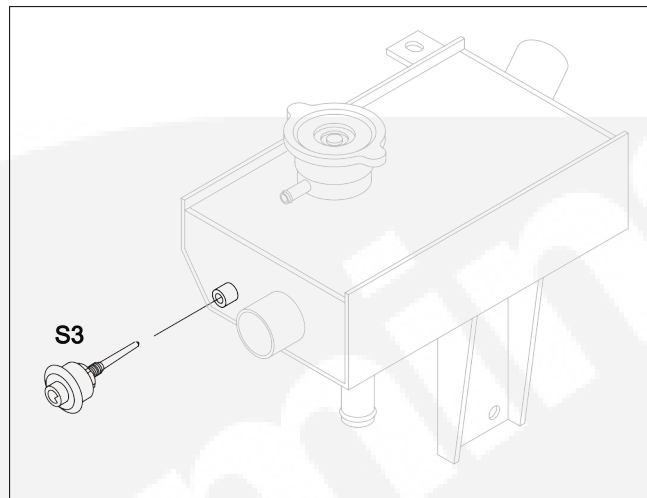

FIGURE 29. MDKDP, MDKDR, MDKDV

4.12.2 Low Coolant Level Switch (S3)

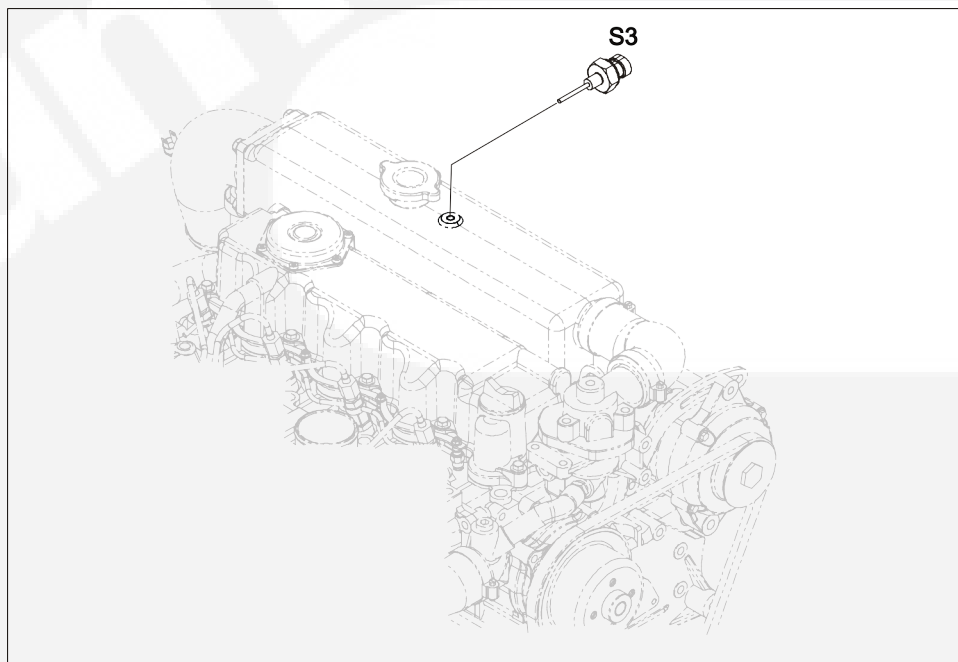

FIGURE 30. MDKDS, MDKDT, MDKDU

4.13 Glow Plug Relay (K3)

The glow plug relay is mounted in its wiring socket inside the generator set control box.

To test the relay:

1. Remove the relay from the socket.
2. Apply battery voltage (12 VDC) across terminals 85-86.

3. Replace the relay if the contacts across terminals 30-87 do not close.

4.14 Starter Relay (K4)

The starter relay is mounted in its wiring socket on the controller mounting bracket.

To test the relay:

- Remove the relay from the socket.
- Apply battery voltage (12 VDC) across terminals 85-86.
- Replace the relay if the contacts across terminals 30-87 do not close.

4.15 Governor Actuator (A12)

The generator set controller modulates the pulse width of the current it sends to governor actuator (A12), which positions the engine fuel rack accordingly.

If troubleshooting indicates that the actuator might be malfunctioning, disconnect its two leads and remove the actuator. Replace the actuator if the plunger does not move smoothly when pushed in or the internal spring does not return it smoothly. If the plunger moves smoothly without binding, apply battery voltage (12 or 24 volts, depending on the generator set) and observe the plunger. Replace the actuator if the plunger does not pull in all the way and stay in while power is applied.

Reinstall the actuator with a new flange gasket. Torque the two mounting screws to 9.5-12.2 Nm (7-9 ft-lb).



4.15.1 Governor Actuator

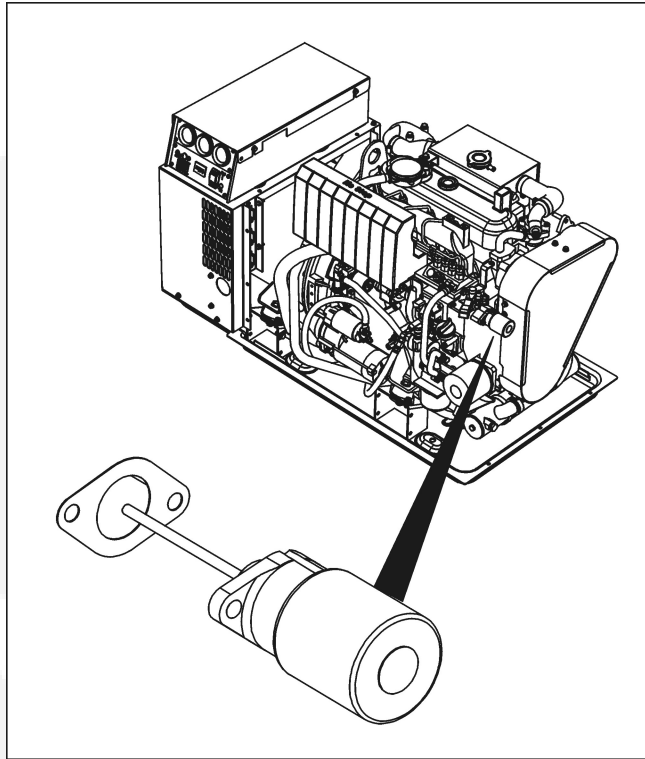

FIGURE 31. MDKDP, MDKDR, MDKDV

4.15.2 Governor Actuator

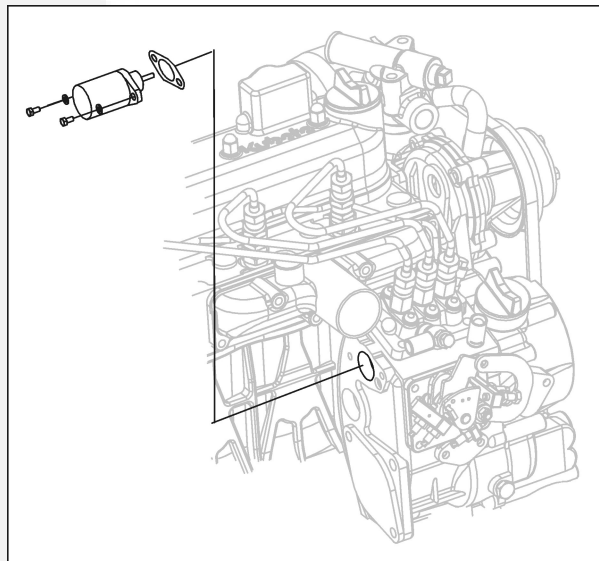

FIGURE 32. MDKDS, MDKDT, MDKDU

4.16 Network Interface Module (NIM)

The optional NIM board has an open 12-pin connector socket for external network connections that mates with a Deutsch® 12-pin sealed connector plug, part number DT06-12S. See illustration below for NIM board mounting location.

See [Appendix A on page 115](#) for connection information.

NOTICE

For more information on SAE 1939 applications see your Cummins Onan distributor. Cummins Onan publication D-3315, *Supported Messages on SAE J1939*, must be used in designing the interface for monitoring generator set status and diagnostics.

NOTICE

For more information on SmartCraft™ applications see your Cummins MerCruiser Distributor.

4.16.1 NIM Mounting Location

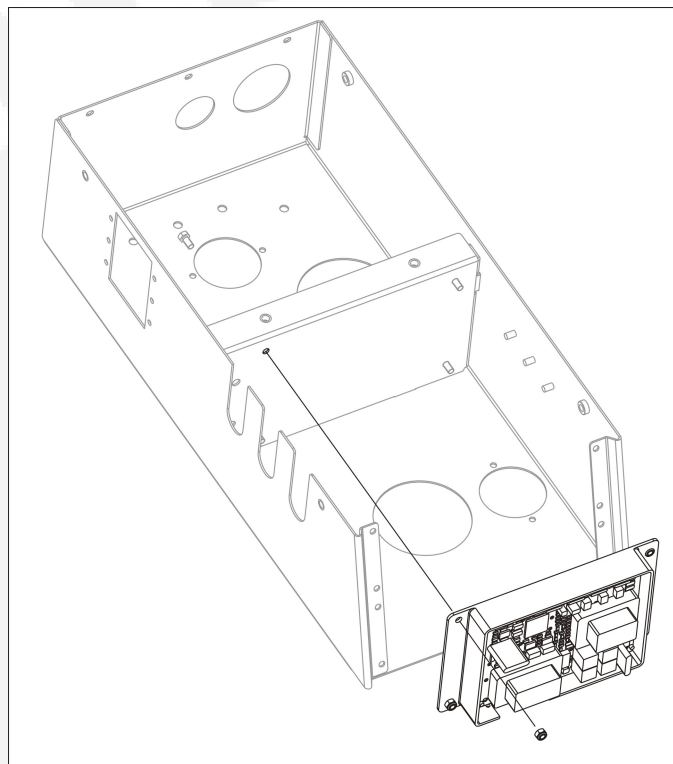

FIGURE 33. NIM MOUNTING LOCATION

4.16.2 NIM Configuration Jumpers

The NIM board has 5 jumpers to configure the board for the specific application, as shown below.

1. Jumper W1 has no function at this time.

2. Jumper W2 will be cut when the generator set is ordered for an SAE J1939 or NMEA 2000™ network application. The jumper must remain uncut when the generator set is ordered for a SmartCraft™ network application.
3. Jumpers W3 and W4 are used to assign the network addresses of the generator sets in a multiple-generator set installation. To assign an address, cut the jumpers as shown below.

TABLE 3. J1939 ADDRESSES

Jumper W3	Jumper W4	Address
Not Cut	Not Cut	234
Not Cut	Cut	158
Cut	Not Cut	179
Cut	Cut	203

4. Cut Jumper W5 if the bus termination resistor on this NIM board is not required to terminate the network bus. (The jumper is cut on a SmartCraft™ board.)

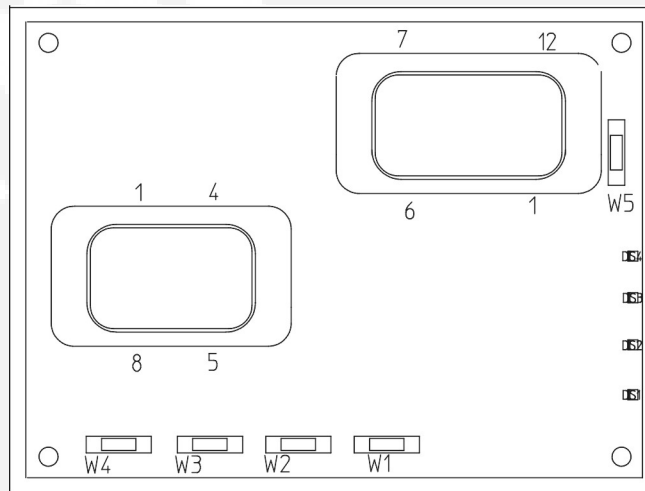
**FIGURE 34. NIM CONFIGURATION JUMPERS**

4.16.3 Troubleshooting LEDs

1. The NIM must be awake to communicate. To wake up the NIM, press the start switch on the generator set. The NIM will always be awake when the generator set is running. If there is no communication activity, it will turn itself off in 5 to 10 minutes after the generator set stops.
2. LED indicator light DS2 blinks very fast when communicating with the generator set. If it does not, check that the Y-harness is connected to 8-pin connector J10 on the NIM and generator set remote connector J4 inside the control junction box. See [Appendix A on page 115](#).
3. LED indicator light DS4 blinks approximately once a second when communicating with the network. If it does not, check that the network harness is connected to 12-pin connector J11 on the NIM. If it still does not communicate, troubleshoot the network harness.
4. LED indicator lights DS1 and DS3 are not used at this time.

4.16.4 Troubleshooting Network

1. Make sure the NIM has been configured properly with its jumpers.
2. Disconnect the network harness at 12-pin connector J11 on the NIM and measure resistance across pins 4 and 5 in the mating network harness connector. The resistance should be 60 ohms, indicating that there is a terminating resistor at each end of the network and that the wiring is intact.
3. Make sure that CAN HI (or CAN +) matches CAN HI on the display and rest of the network.

4.17 NMEA 2000 Network Protocol

The figure below shows the connection for the optional NMEA 2000™ communication protocol on the generator set. For more information, see the installation instructions in the kit.

NOTICE

The generator data on the NMEA 2000 network has been set with an instance value of 10, as shipped from the factory. In order to view the generator data over the NMEA 2000 network, applicable displays and gauges will need to be set to read the generator data on instance 10.

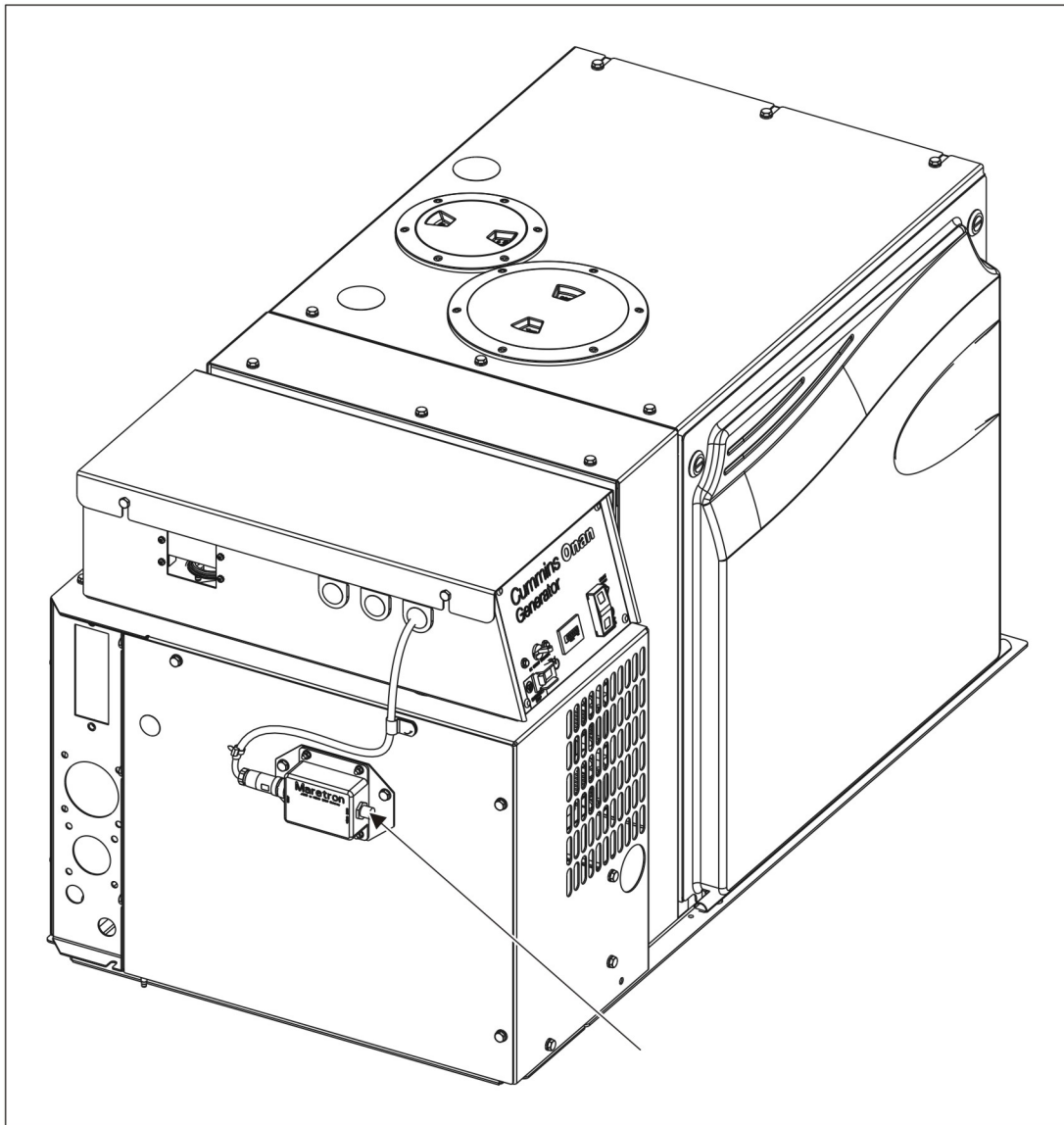

FIGURE 35. NMEA 2000 CUSTOMER CONNECTION

5 Engine and Accessories

5.1 Major Engine Service

⚠ WARNING

***Accidental or remote starting.
Accidental or remote starting of the generator set can cause severe personal injury or death.
Prevent accidental or remote starting by disconnecting the starting battery cables (negative [-] first), using an insulated wrench and isolating all auxiliary supplies.***

Refer to the Engine Workshop Manual for major engine service. See the Specifications Section ([Chapter 9 on page 105](#)) in this manual to identify the engine model number for the generator set.

When remounting the engine torque the vibration isolator through bolts to 37-44.7 Nm (27-33 ft-lb).

5.2 Exhaust Manifold

⚠ WARNING

Accidental or remote starting can cause severe personal injury or death. Before removing a panel or access door, disconnect the negative (-) cable at the battery to prevent the engine from starting.

MDKDS, MDKDT, MDKDU: ([Figure 36](#)) When reassembling, use new manifold and mixer gaskets. Torque the manifold nuts (2 per port) and mixer flange bolts to 23.4-28.6 Nm (17.1-20.9 ft-lb).

MDKDP, MDKDR, MDKDV: ([Figure 37](#)) When reassembling, use new manifold and mixer gaskets. Torque the manifold nuts (2 per port) and mixer or dry exhaust flange bolts (4) to 21-32 Nm (16-23 ft-lb). Torque the wet exhaust hose adapter flange bolts (3) to 8.7-13.0 Nm (6.4-9.6 ft-lb).

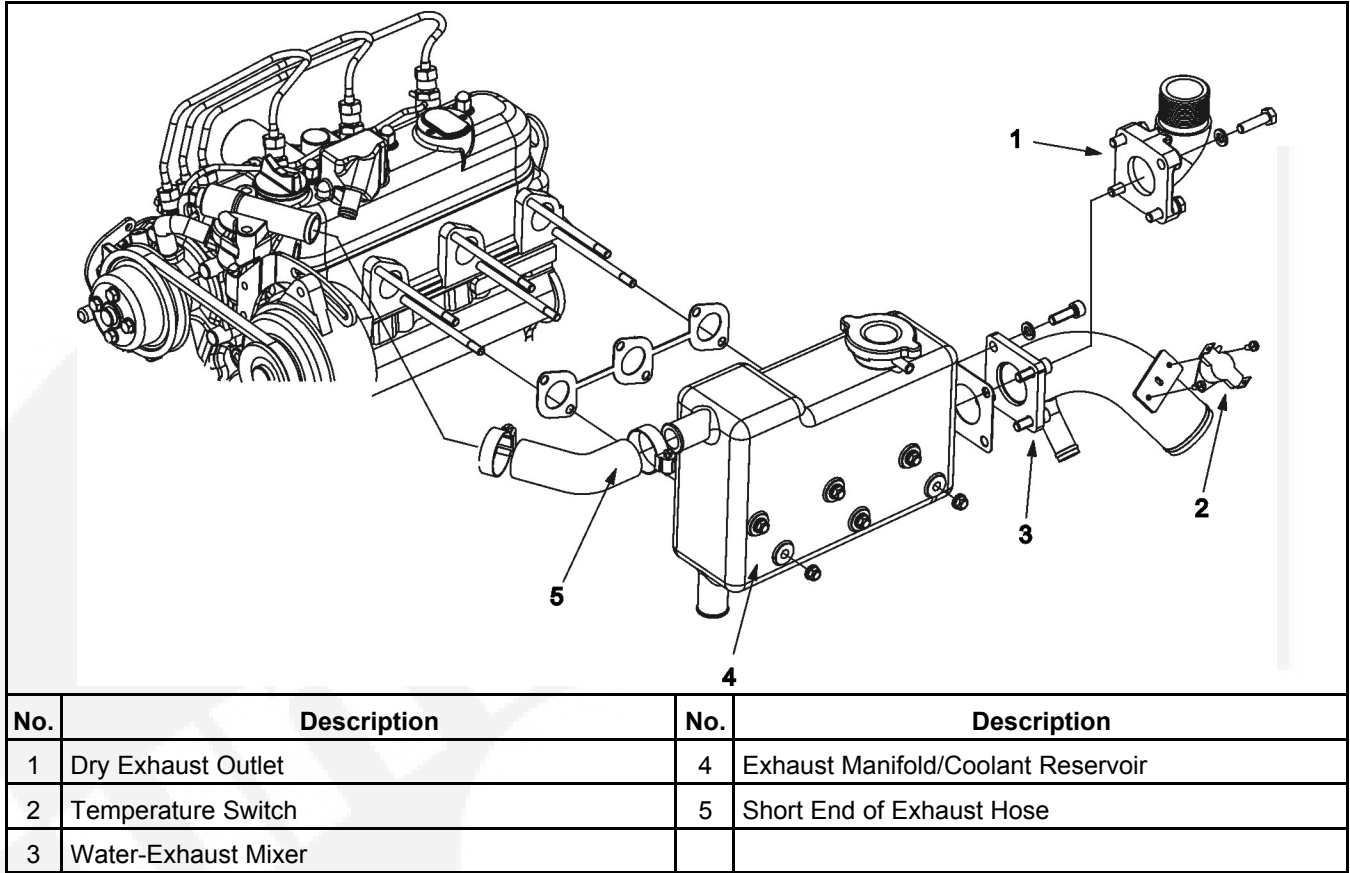

FIGURE 36. MDKDS, MDKDT, MDKDU

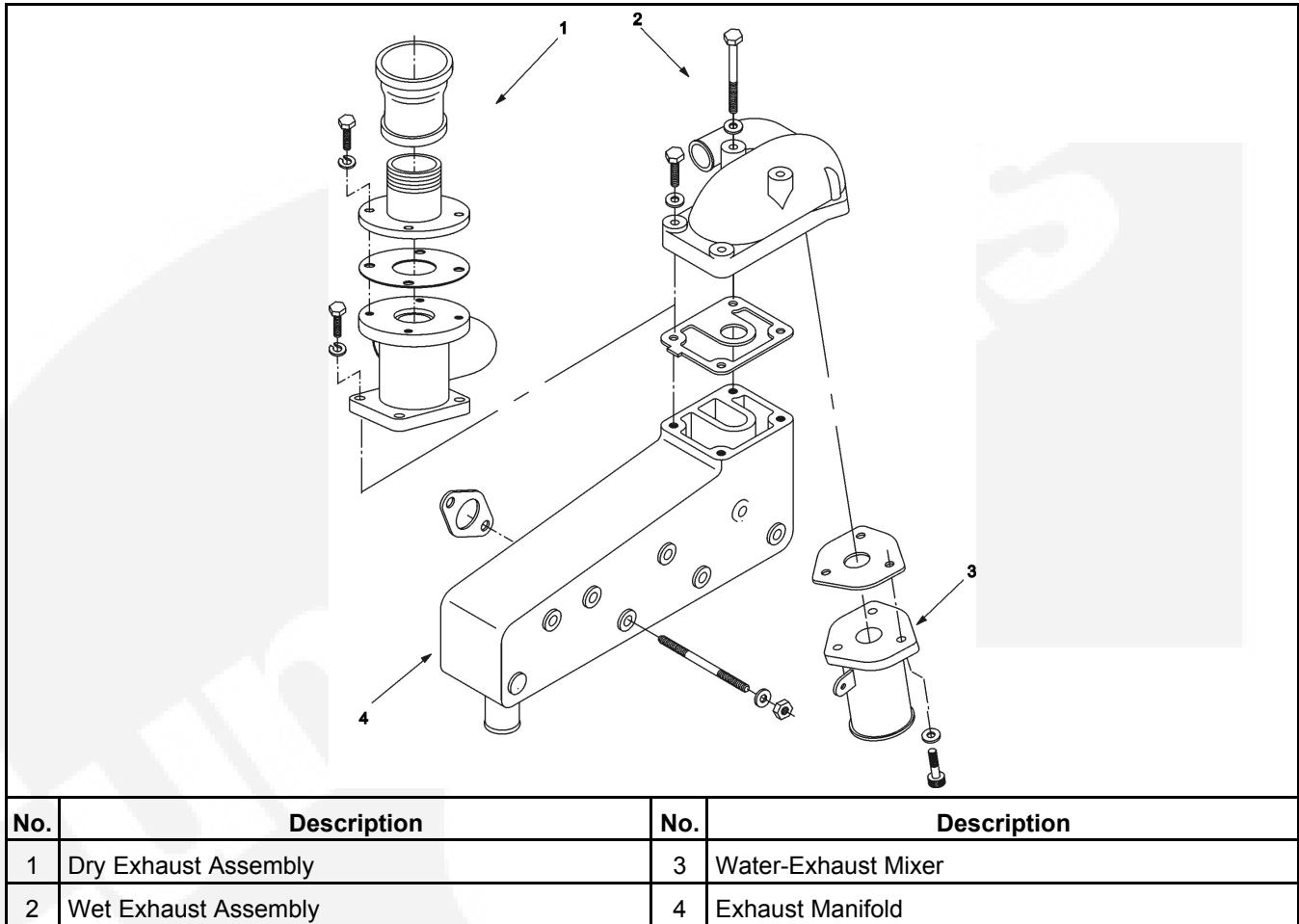

FIGURE 37. MDKDP, MDKDR, MDKDV

5.3 Fuel System

⚠ WARNING

Accidental or remote starting can cause severe personal injury or death. Before removing a panel or access door, disconnect the negative (-) cable at the battery to prevent the engine from starting.

⚠ WARNING

Diesel fuel is combustible and can cause severe personal injury or death. Do not smoke near fuel tanks or fuel-burning equipment or in areas sharing ventilation with such equipment. Keep flames, sparks, pilot flames, electrical arcs and switches and all other sources of ignition well away. Keep a multi-class fire extinguisher handy.

The figure below illustrates the fuel system and glow plug location.
See the Engine Workshop Manual for fuel injection system service.

5.3.1 Fuel System

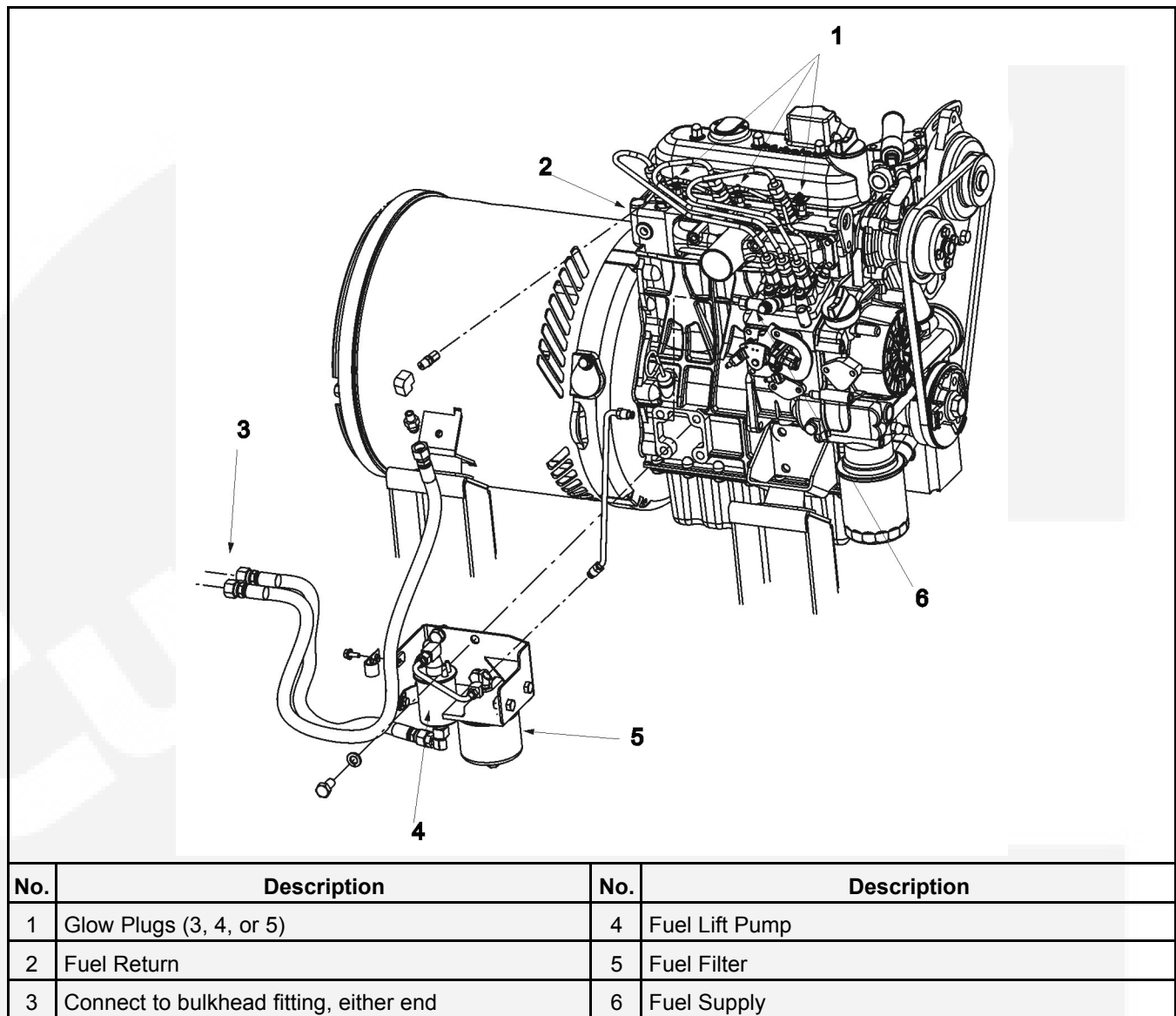

FIGURE 38. TYPICAL FUEL SYSTEM

5.3.2 Fuel Filter

For fuel filter maintenance, see [Section 3.5 on page 29](#).

5.3.3 Fuel Pump Test

A quick test to determine if the fuel pump is weak is to pinch the fuel bypass hose with rubber-tipped vise grips. If an engine that fails to start, starts and runs with bypass flow cut off, fuel delivery to the engine is weak. Service all fuel filters in the system and repair any restrictions to fuel flow. If fuel delivery is still weak, test the fuel lift pump.

To test fuel lift pump delivery:

1. Disconnect the fuel return hose from the line to the supply tank and point the end into a container of known volume, such as a 1 or 2 liter (quart) bottle.
2. Prime the generator set by pushing the Start/Stop switch to STOP (Prime) and hold it there for the duration of the test. It should not take longer than 1-1/2 minutes to fill a 1 liter container (2/3 liter per minute).
3. If flow is less than specified above, service all of the fuel filters in the system and repair any restrictions to fuel flow. If fuel delivery is still weak, replace the fuel lift pump.

5.3.4 Fuel Pump Removal and Installation

Remove the right side panel for access.

Alternatively, if the starter has been removed from the front, the fuel pump can also be removed from the front.

5.3.5 Fuel Fittings

The connections for fuel supply and return are pipe threaded fittings. Use liquid-type pipe thread sealant listed as suitable for diesel fuel. Apply the sealant sparingly to the male threads only.

⚠ CAUTION

Excess liquid-type pipe thread sealant or pieces of Teflon-type pipe thread sealant can plug the engine fuel system. Apply liquid-type pipe thread sealant sparingly to the male threads only. Do not use Teflon tape.

5.3.6 Fuel Hose

Replace worn or damaged fuel hoses with USCG TYPE A1 or ISO 7840-A1 fuel hose. The hoses must be long enough to be clamped and routed under the oil pan without rubbing on the oil pan.

If so equipped, the second intake resonator chamber must be removed to connect and disconnect the supply hose at the fuel injector.

5.3.7 Glow Plugs

Refer to the Engine Workshop Manual when replacing the glow plugs. See [Section 5.3 on page 67](#) for glow plug location illustration.

NOTICE

If a glow plug does not come out after unscrewing it, or the end has broken off, it will be necessary to remove the engine head. Glow plugs can swell if preheat voltage is greater than 14 volts, such as when a battery booster is used for starting.

Inspect the glow plugs as follows.

1. Check for B+ at the glow plug terminals during cranking. If there is no B+, remove the glow plug relay K3 from its socket, test for proper operation ([Section 4.13 on page 58](#)), and replace if necessary.

2. Check for B+ at relay socket terminal 30 for continuity between terminal 87 and the glow plugs, and for continuity between terminal 86 and B- (ground).
3. Clean and tighten connections and replace wiring as necessary.
4. Check for B+ at relay socket terminal 85 while cranking. If there is no B+, disconnect connector P1 (black) from the generator set controller and check for a missing, bent or corroded Pin 1 and for faulty wire and repair as necessary.
5. Remove the glow plug bus bar and check for electrical continuity between each glow plug terminal and B- (ground).
6. Replace any open glow plug.

5.4 Starter

WARNING

Accidental or remote starting.

Accidental or remote starting of the generator set can cause severe personal injury or death.

Prevent accidental or remote starting by disconnecting the starting battery cables (negative [-] first), using an insulated wrench and isolating all auxiliary supplies.

The starter motor is bolted to the flywheel housing. For access, remove the right side enclosure panel. See the Engine Workshop Manual for service or replacement. Parts are available for rebuilding the starter. Torque the mounting bolts to 39 Nm (29 ft-lb).

5.4.1 Negative Ground Connection

1. Install the starter motor.
2. Check to sure that the engine block is grounded properly, depending on whether standard or isolated ground connections are required.
3. Install the star washer between the engine block and cables.
4. Torque the bolt to 55 Nm (41 ft-lb).

5.4.2 Ground Isolation Relay (K9)

This relay is accessible after the starter or side panel has been removed.

When required, the generator set is equipped with isolation relay K9 to isolate the negative (-) battery terminal from the vessel grounding system while the generator set is running. (The engine block is connected to battery negative [-] during starting.) Replace the relay if its contacts do not close when 12 VDC voltage is applied to the coil terminals.

5.4.3 Starter Motor Mounting

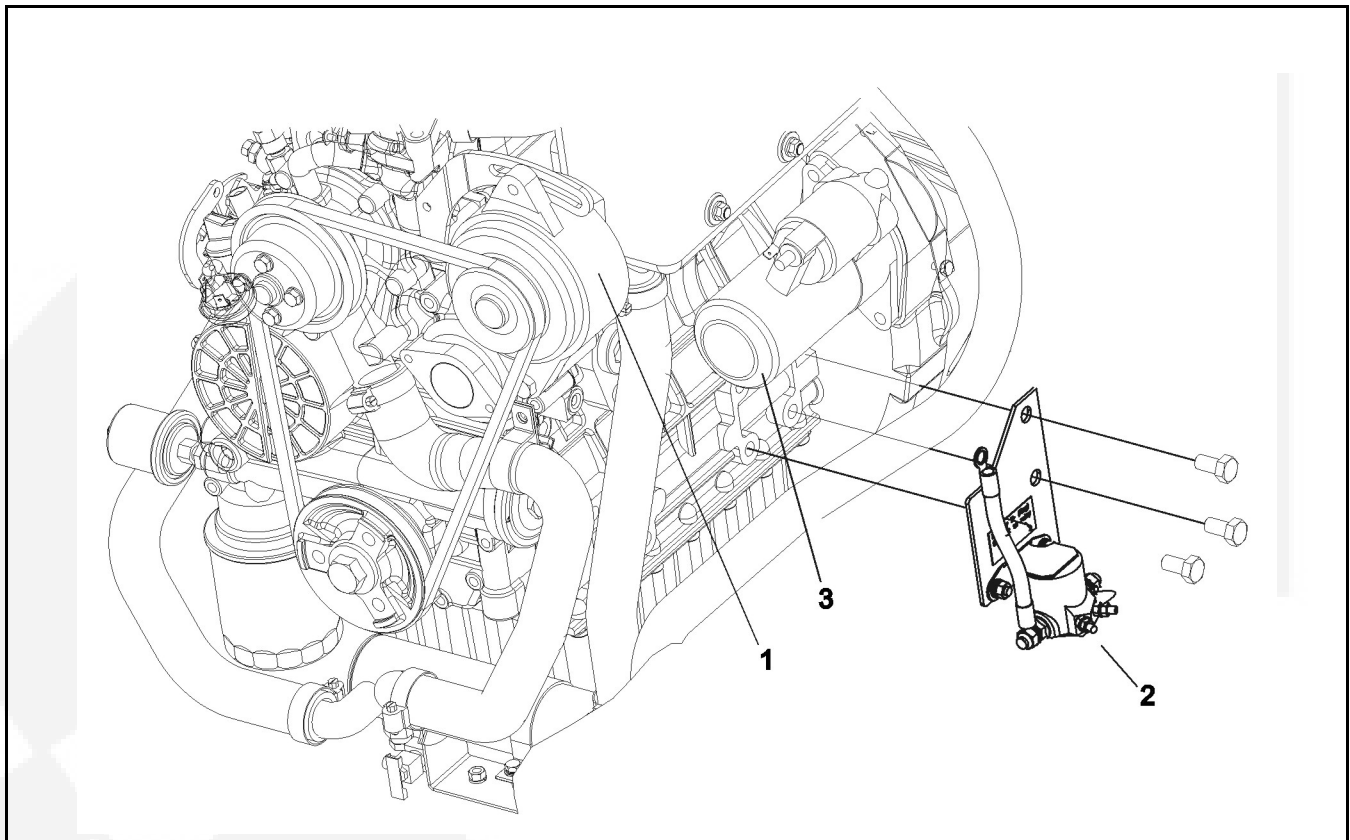

No.	Description	No.	Description
1	Battery Charging Alternator	3	Starter Motor (other side on MDKDP, MDKDR, MDKDV)
2	Relay K9		

FIGURE 39. TYPICAL STARTER MOTOR, BATTERY CHARGING ALTERNATOR, AND B- ISOLATING RELAY

5.5 Raw Water Pump

The engine is equipped with a raw water pump only on models with wet exhaust or wet exhaust and heat exchanger.

See Replacing the Raw Water Pump Impeller Section in the Maintenance Chapter for instructions on how to replace the impeller. Kits are available for servicing the raw water pump. Follow the instructions in the kit.

5.6 Battery Charging Alternator

See Adjusting V-belt Tension in the Maintenance Chapter to adjust or replace the alternator V-belt. See the Engine Workshop Manual in the Related Literature Section of the Introduction Chapter for service or replacement.

This page is intentionally blank.



6 Alternator

6.1 Overview

⚠ WARNING

***Accidental or remote starting.
Accidental or remote starting of the generator set can cause severe personal injury or death.
Prevent accidental or remote starting by disconnecting the starting battery cables (negative [-] first), using an insulated wrench and isolating all auxiliary supplies.***

These are 4-pole, rotating-field, brushless, single-bearing generators. The figure below identifies the typical generator components.

The engine rotates the generator field (main rotor) to induce output current (AC) in the main stator windings. Generator output is proportional to the main rotor (field) current supplied by the exciter rotor through its full-wave rectifier bridge (rotating rectifiers).

The generator set controller ([Chapter 4 on page 45](#)) rectifies and modulates quadrature winding output (Q1, Q2) to supply the exciter stator (F1, F2). By comparing generator output voltage with a reference value, the generator set control regulates field current to maintain nominal output voltage as load varies. Also, in response to transient loads, it lowers the voltage setpoint to allow for engine recovery.

Residual field magnetism and a permanent magnet in one of the exciter stator poles initiates self-excitation during startups.

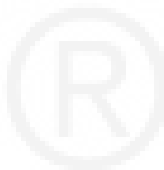

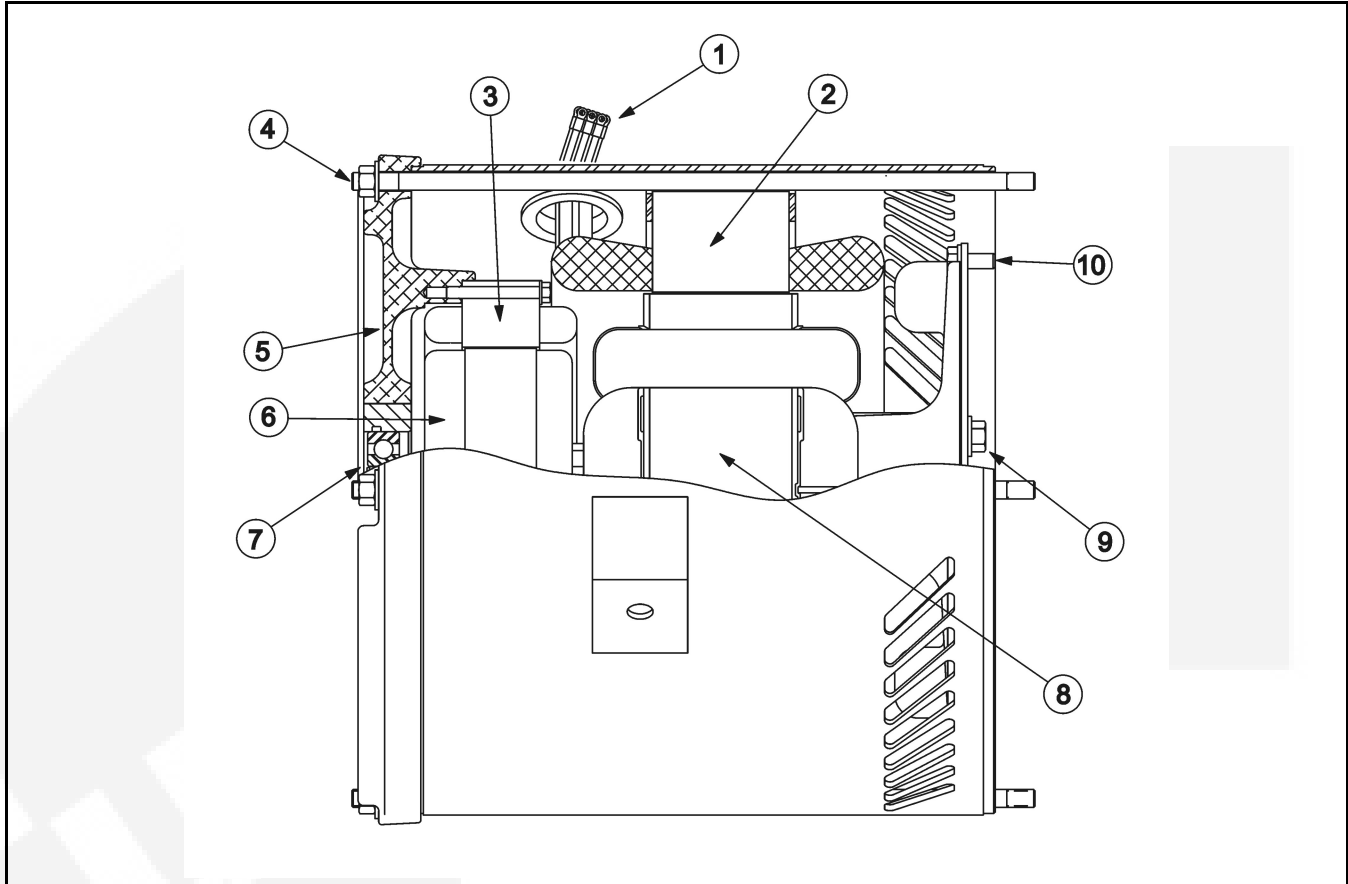

No.	Description	No.	Description
1	Stator, Quadrature, Field, and Voltage Sensing Leads	6	Exciter Rotor
2	Generator Stator (Main and Quadrature Windings)	7	Rotor Bearing
3	Exciter Stator	8	Main Rotor (Field)
4	Through Bolt (4) Torque Dry to 38–43 Nm (28–32 ft-lb)	9	Disc Hub Bolt (6) Torque Dry to 50–57 Nm (37–42 ft-lb) Smooth, rounded sides of washers toward disc
5	End Bell Assembly	10	Disc Hub Bolt (6) Torque Dry to 27–31 Nm (20–23 ft-lb) Smooth, rounded sides of washers toward disc

FIGURE 40. TYPICAL GENERATOR

6.1.1 Generator Stator and Winding Resistances

TABLE 4. GENERATOR STATOR AND WINDING RESISTANCES

Model Name	Main Winding Resistance Ohms (1,2)	Quadrature Winding Resistance Ohms (1)	Main Stator Resistance Ohms (1)	Exciter Rotor Resistance Ohms (1)	Exciter Stator Resistance Ohms (1)
4-Lead Generators (Single Phase)					
MDKDP	0.078-0.086	0.807-0.897	2.32-2.56	0.58-0.71	13-16

Model Name	Main Winding Resistance Ohms (1,2)	Quadrature Winding Resistance Ohms (1)	Main Stator Resistance Ohms (1)	Exciter Rotor Resistance Ohms (1)	Exciter Stator Resistance Ohms (1)
MDKDR	0.055-0.061	0.658-0.728	2.77-3.06	0.58-0.71	13-16
MDKDS	0.025-0.028	0.483-0.533	2.97-3.27	0.58-0.71	13-16
MDKDT	0.029-0.032	0.506-0.560	2.57-2.87	0.58-0.71	13-16
MDKDU	0.025-0.028	0.483-0.533	2.97-3.27	0.58-0.71	13-16
MDKDV	0.055-0.061	0.658-0.728	1.89-2.32	0.58-0.71	13-16
12-Lead Generators (Three Phase)					
MDKDP	0.172-0.191	2.347-2.594	2.54-3.10	0.58-0.71	13-16
MDKDR	0.105-0.117	1.853-2.048	2.17-2.65	0.58-0.71	13-16
MDKDS	0.054-0.068	0.80-0.91	2.77-3.06	0.58-0.71	13-16
MDKDT	0.056-0.062	0.865-0.956	2.32-2.56	0.58-0.71	13-16
MDKDU	0.054-0.068	0.80-0.91	2.77-3.06	0.58-0.71	13-16
MDKDV	0.105-0.117	1.853-2.048	2.20-2.68	0.58-0.71	13-16
1. If high, recheck winding resistance after the windings have cooled to room temperature. 2. The main windings are probably good if some of the resistances fall outside the range but are all within 10 percent of each other.					

6.2 Winding Insulation Resistance Test Procedure

A 500 VAC megger is recommended for the winding insulation resistance tests prescribed below. A test consists of applying the test potential between the winding and ground (winding laminations) for a period of 10 minutes and recording resistance at 1 minute and again at 10 minutes.

Resistance values of at least 5 megohms should be obtained for a new generator with dry windings. The polarization index should also be at least 2 (the ratio of the resistance reading at ten minutes to the reading at one minute). For a set that has been in service, the resistance reading should not be less than 1 megohm nor the polarization index less than 2.

Dry the windings if low readings are obtained or the set has been in standby for a long time in high humidity conditions and repeat the test.

6.3 Winding Resistance Test Procedure

Use a digital ohmmeter or Wheatstone bridge to measure winding resistance. The device should have a precision of at least 0.01 ohm.

6.4 Break-Out Tool 300-5512

Break-out tool, part of Tester Electronic UMC Service Kit 420-0624, for use in conjunction with an accurate digital multi-meter, is available for performing winding output tests while running the generator set. The tool is plugged into the generator set wiring harness in place of the generator set control. Follow the tool instructions.

6.5 Exciter Stator

6.5.1 Winding Insulation Resistance

Test - Connect pin P3-7 or P3-6 to the megger and conduct the test as instructed under Winding Insulation Resistance Test Procedure.

Disassembly - Disconnect generator set control connector P3.

6.5.2 Winding Resistance

Test - Measure winding resistance between pins P3-7 and P3-6.

Action - Replace the exciter stator if the resistance is not as specified in [Table 4 on page 74](#).

6.5.3 Exciter Stator and End Bell

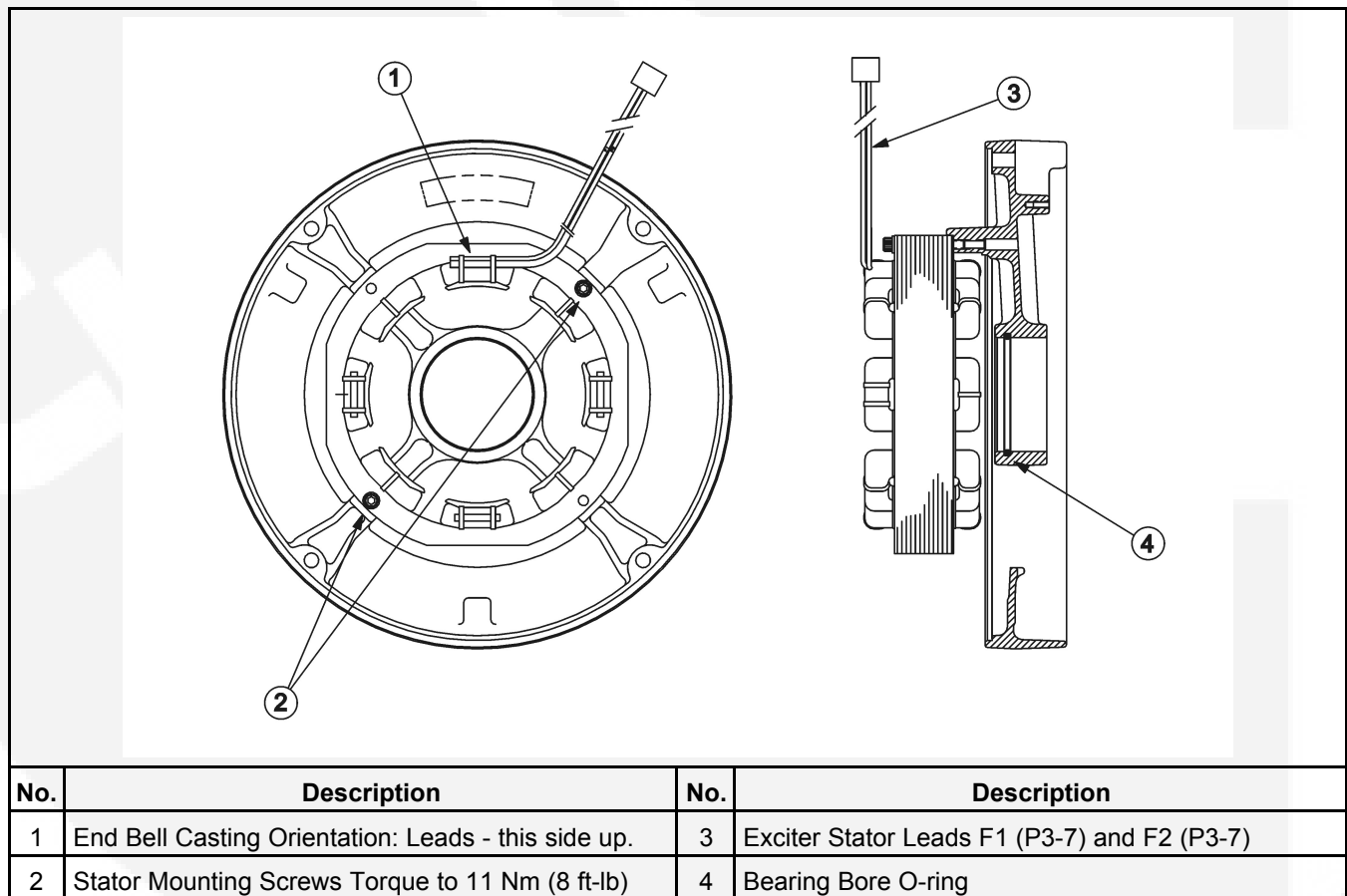

FIGURE 41. EXCITER STATOR AND END BELL

6.6 Exciter Rotor

6.6.1 Winding Insulation Resistance

Test - Connect any lead to the megger and conduct the test as instructed under Winding Insulation Resistance Test Procedure.

Disassembly - Disconnect all six exciter rotor leads from diode terminals CR1 through CR6 and isolate them from ground.

6.6.2 Winding Resistance

Test - Measure electrical resistance across each pair of rotor windings: T11-T12, T21-T22, T12-T13, T22-T23, T13-T11 and T23-T21. See the connection schematic.

Action - Replace the exciter rotor if the resistance of any winding is not as specified in [Table 4 on page 74](#).

6.7 Rotating Rectifiers

The rotating rectifier assembly consists of two diode assemblies, one positive and one negative. Each assembly contains the following:

- Three diodes
- Three terminals to connect to the appropriate lead of the exciter rotor (CR1, CR2, and CR3, or CR4, CR5, and CR6)
- One field terminal (F1+ or F2-) to connect leads from the main rotor (generator field).

The rotating rectifier assembly is mounted on the back face of the exciter rotor.

Test

Use the diode test function on the test meter to test the six diodes in the rotating rectifier assembly. In the forward bias direction the meter should indicate 0.5 to 0.8 volts. In reverse bias direction the meter should indicate open.

1. Isolate Diodes - Disconnect the lead at each diode terminal (CR1, CR2, and CR3, or CR4, CR5, and CR6) to make sure all of the meter test current flows only through the diode being tested.
2. Test Reverse Bias on Positive Rectifier - Touch meter positive to field terminal F1+ and meter negative to diode terminals CR1, CR2, and CR3.
3. Test Forward Bias on Positive Rectifier - Touch meter negative to field terminal F1+ and meter positive to diode terminals CR1, CR2, and CR3.
4. Test Reverse Bias on Negative Rectifier - Touch meter negative to field terminal F2- and meter positive to diode terminals CR4, CR5, and CR6.
5. Test Forward Bias on Negative Rectifier - Touch meter positive to field terminal F2- and meter negative to diode terminals CR4, CR5, and CR6.

Action

Replace the rectifier assembly if the meter indicates that any diode is open in both directions or is shorted (zero ohms and/or audible signal).

1. Disconnect all leads from the defective diode assembly.
2. Remove the two mounting screws.
3. Make sure the replacement diode assembly is of the correct polarity, positive (+) or negative (-).
4. Attach the new diode assembly with two mounting screws.
5. Reconnect all leads.
6. Torque the terminal screws to 2.6 Nm (24 in-lb).

Assembly

Reconnect the lead at each diode terminal.

1. Reconnect the lead at each diode terminal.
2. Torque the terminal screws to 2.6 Nm (24 in-lb).

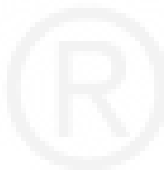

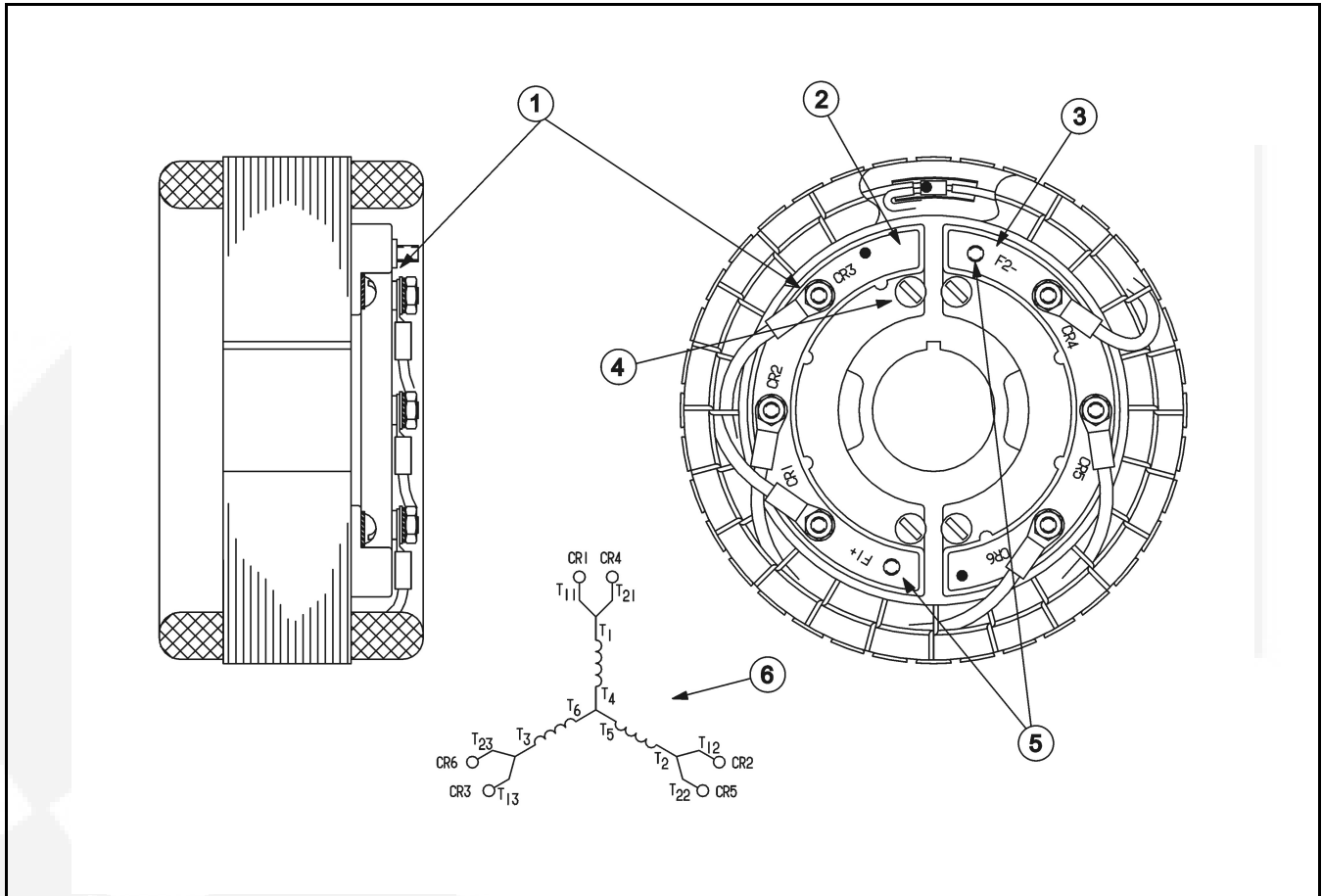

No.	Description	No.	Description
1	Diode Terminals (6) for Exciter Winding Lead. Torque to 2.6 Nm (24 in-lb). Use flat washer to protect lead connector.	4	Diode Assembly Mounting Screws (2)
2	Positive (+) Diode Assembly. Left-Hand Side, Shaft Key Up.	5	Terminals F1+ and F2- for Main Rotor Leads. Torque to 2.6 Nm (24 in-lb)
3	Negative (-) Diode Assembly. Right-Hand Side, Shaft Key Up.	6	Connection Schematic

FIGURE 42. ROTATING RECTIFIER ASSEMBLY

6.8 Main Rotor

6.8.1 Winding Insulation Resistance

Test - Connect either or both leads to the megger and conduct the test as instructed under Winding Insulation Resistance Test Procedure.

Disassembly - Disconnect the main rotor leads from terminals F1+ and F2+ on the rotating rectifier assemblies and isolate them from ground. Tag and mark each lead with its terminal number (F1+ or F2+).

⚠ CAUTION

Because of the opposing residual magnetism of the rotor, it might be difficult to re-establish self excitation if the polarity of the main rotor leads is reversed upon reassembly.

6.8.2 Winding Resistance

Test - Measure electrical resistance between terminals F1+ and F2+.

Action - Replace the rotor if the resistance is not as specified in [Table 4 on page 74](#).

Disassembly - Disconnect the main rotor leads from terminals F1+ and F2+ on the rotating rectifier assemblies

Assembly - Reconnect the rotor leads and torque the terminals to 2.7 Nm (24 in-lb) when reassembling.

6.8.3 Rotor Assembly

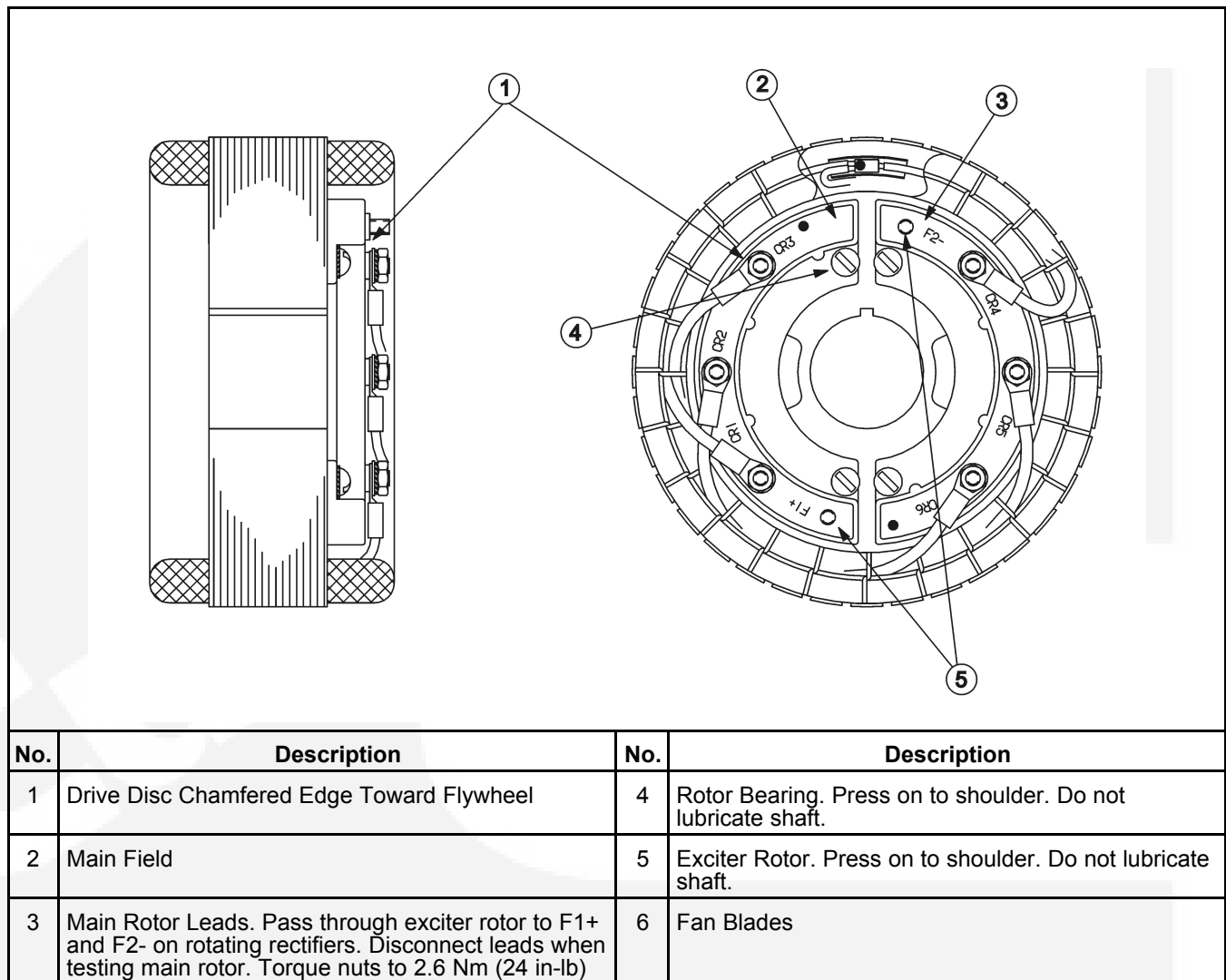

FIGURE 43. ROTOR ASSEMBLY

6.9 Main Stator

6.9.1 Winding Insulation Resistance

Test - Test each winding separately. Connect either or both winding leads to the megger and conduct the test as instructed under Winding Insulation Resistance Test Procedure.

Disassembly - Disconnect the winding lead from its grounded neutral connection and isolate it. Leave the other windings grounded.

6.9.2 Winding Resistance

Test -

- For 4-Lead generators measure resistance across lead pairs: T1-T2, T3-T4

- For 12-Lead generators measure resistance across lead pairs: T1-T4, T2-T5, T3-T6, T7-T10, T8-T11, T9-T12

Action - Replace the stator assembly if the resistance of any winding is not as specified in [Table 4 on page 74](#).

Disassembly - Disconnect all main stator leads from the terminals to which they are connected.

6.9.3 Quadrature Winding Insulation Resistance

Disassembly

Disconnect generator set control connector P3.

Test

1. Connect a megger to connector P3 pin 4 or pin 5.
2. Do the Winding Insulation Resistance Test Procedure.

6.9.4 Quadrature Winding Resistance

Test

Use a Wheatstone bridge to measure winding resistance between pins P3-4 and P3-5.

Action

Replace the stator assembly if the resistance is not as specified in the Generator Stator and Winding Resistances table in the beginning of the chapter.

6.9.5 Winding to Winding Insulation Resistance

Test

Check stator winding-to-winding insulation resistance between the following lead pairs as instructed under Testing Winding Insulation Resistance:

4-Lead Generators		12-Lead Generators			
From	To	From	To	From	To
T1	T3	T1	T2	T3	T8
T2	P3-4	T1	T3	T3	T9
T3	P3-4	T1	T7	T7	T8
		T1	T8	T7	T9
		T1	T9	T8	T9
		T2	T3	T1	P3-4
		T2	T7	T2	P3-4
		T2	T8	T3	P3-4
		T2	T9	T7	P3-4
		T3	T7	T8	P3-4
				T9	P3-4

Disassembly

Disconnect generator set control connector P3 and all main stator leads from the terminals to which they are connected.

Assembly

Reconnect generator set control connector P3 and all main stator leads.

6.10 Generator Disassembly

⚠ WARNING

Accidental starting can cause severe personal injury or death. Disconnect the negative (-) cable or cables at the battery or batteries to prevent the generator from starting.

⚠ WARNING

Accidentally dropping the generator can damage it and cause severe personal injury or death. Use a hoist and straps of sufficient capacity and attach them so that the load cannot shift.

⚠ CAUTION

The generator drive plates will be damaged if the rotor is used to support the stator during assembly or disassembly of the generator. The generator drive plates will be damaged if the rotor is used to support the stator during assembly or disassembly of the generator.

The generator is heavy. You will need a hoist of sufficient capacity.

1. Disconnect all power output connections, remote control connections, and conduit at the generator. Label each lead clearly to make reconnections easier.
2. Disconnect all engine harness connections and grounding straps in the control box.
3. Disconnect all generator leads from connections in the output box.
4. Disconnect connectors P1, P2 and P3 from the generator set controller.
5. Disconnect connector P8 (some models) or disassemble the pins for generator leads Q1, Q2, F1, F2, S1, S2 from connector P3.
6. Remove the control box, output box and saddle as an assembly.
7. Attach a hoist to the generator set lifting eye.
8. Remove the throughbolts in the two generator mounts.
9. Tip the generator end up slightly with the hoist.
10. Block the flywheel housing to support the engine while the generator is being serviced.
11. Cinch a strap around the middle of the generator stator and take up slack with the hoist.
12. On models with stator through bolts:
 - a. Scribe lines before separating the end bell from the stator and the stator from the flywheel housing to register the parts for reassembly.
 - b. Remove the 4 nuts on the through bolts.

- c. Tap the end bell free of the stator.
 - d. Tap the stator free of the flywheel housing.
 - e. Carefully draw the stator straight back until it clears the ends of the through bolts.
 - f. Remove the through bolts.
13. On models with flange bolts:
 - a. Remove the end bell and generator-to-engine flange bolts.
 - b. Carefully draw the stator straight back until it clears the end of the rotor.
 14. Cinch a strap around the rotor.
 15. Remove the 6 disc-to-flywheel bolts ([Figure 40 on page 74](#)).
 16. Cradle the rotor horizontally in wooden blocks to prevent damage to windings, laminations, and drive disc.
 17. Use a gear puller to remove the rotor bearing or exciter rotor ([Figure 40 on page 74](#)).

6.11 Generator Reassembly

Reassembly is the reverse of disassembly. Note the following when reassembling the generator:

1. Press a new exciter rotor or rotor shaft bearing on up to its locating shoulder on the shaft. Do not lubricate the shaft ([Figure 40 on page 74](#)).
2. Torque the 6 or 8 disc-to-hub bolts to 50-57 Nm (37-42 ft-lb). Make sure that:
 - The chamfered edge on the drive disc perimeter faces out to make assembly with the flywheel easier.
 - The rounded edges of the washers are on the disc side.
3. Torque the 6 or 8 disc-to-flywheel bolts to 27-31 Nm (20-23 ft-lb). Make sure the rounded edges of the washers are on the disc side.
4. On models with a generator-to-engine flange, torque the flange bolts to 50-60 Nm (37-45 ft-lb) and the end bell flange bolts to 9 Nm (8 ft-lb)
5. On models with stator through bolts, use the 4 through bolts to help guide the stator on. Thread the ends with less thread into the flywheel housing and make sure the threads bottom.
6. On models with stator through bolts, make sure the scribed stator-flywheel index lines register ([Step 5 on page 83](#)).
7. Torque the two exciter stator screws to 11 Nm (8 ft-lb). The pole to which the leads are tied must be up.
8. Wipe the bearing bore in the end bell lightly with molybdenum disulfide grease and make sure the rubber O-ring is in place.
9. On models with stator through bolts, assemble the end bell to the stator, making sure the scribed index lines ([Step 5 on page 83](#)) register and the rotor bearing seats fully in the bore. Pull the field leads out the same opening as the stator leads. Torque the nuts on the generator through bolts to 38-43 Nm (28-32 ft-lb).
10. Secure the end bell cover plate and torque the 4 screws to 3.8 Nm (8 in-lb).

11. Reassemble all the remaining components. Make sure to resecure the ring terminals of grounding straps and leads with 2 star washers, one on each side, for good electrical continuity. Torque the vibration isolator through bolts to 37-44.7 Nm (27-33 ft-lb).

6.12 Reconnecting the Generator

Reconnect the generator properly for the application. See [Appendix A on page 115](#).

6.13 Line Circuit Breakers

WARNING

***Accidental or remote starting.
Accidental or remote starting of the generator set can cause severe personal injury or death.
Prevent accidental or remote starting by disconnecting the starting battery cables (negative [-] first), using an insulated wrench and isolating all auxiliary supplies.***

The line circuit breakers are mounted in the AC output box.

Test - Check electrical continuity across each pole.

Action - Replace a circuit breaker if either pole does not reset or turn ON and OFF.

Disassembly - Disconnect all leads

Assembly - Reconnect the generator and load wires properly (see [Appendix A on page 115](#)).



This page is intentionally blank.



7 Adjusting AC Output Voltage

7.1 Reconnecting Generator

⚠ WARNING

Accidental or remote starting can cause severe personal injury or death. Before removing a panel or access door, or before working on the generator set, use an insulated wrench to disconnect the negative (-) cable from the battery to prevent accidental starting.

NOTICE

Any attempt to change frequency on an EPA certified generator set will void the warranty, cause the generator set to be out of compliance, and may cause damage to the engine.

If necessary:

1. Reconnect the generator for the application voltage in accordance with the appropriate generator connection schematic (see [Appendix A on page 115](#)).
2. Apply the appropriate reconnection label.
3. Adjust voltage if necessary.

NOTICE

It may be necessary to change circuit breakers to provide required protection or full generator set power when reconnecting the generator.

7.1.1 Reconnection Label

The generator set manuals were shipped with a sheet of peel-off reconnection labels ([Figure 45](#)) to apply to the generator set nameplate ([Figure 44](#)) when reconfiguring the generator set for the application. Apply the appropriate label if different from the original data block.

IMPORTANT ENGINE INFORMATION					
CUMMINS POWER GENERATION					
1400 73rd Ave. NE					
Minneapolis, MN 55432					
Model: <input type="text"/>	Spec: <input type="checkbox"/>	Made in U.S.A.			
S/N: <input type="text"/>	KVA: <input type="text"/>	Pf: <input type="text"/>	KW: <input type="text"/>	PH: <input type="text"/>	RPM: <input type="text"/>
	50 Hz: <input type="text"/>	<input type="text"/>	<input type="text"/>	<input type="text"/>	<input type="text"/>
	60 Hz: <input type="text"/>	<input type="text"/>	<input type="text"/>	<input type="text"/>	<input type="text"/>
As Manufactured:					
Freq: <input type="text"/>	AC Volts: <input type="text"/>	Amps: <input type="text"/>			
Options: <input type="text"/>	Fuel: <input type="text"/>	Bat: <input type="text"/>			
	Software Cfg: <input type="text"/>				
	Wire Diagram: <input type="text"/>				
Insulation - NEMA Class <input type="text"/> Ambient 40°C					
REFER TO OPERATOR'S MANUAL FOR MAINTENANCE SPECIFICATIONS AND ADJUSTMENTS.					
99-2495 <input type="checkbox"/>					

FIGURE 44. ORIGINAL NAMEPLATE

ALTERNATOR RECONNECTION LABEL		
THESE LABELS ARE TO BE USED WHEN GENSET IS REWIRED. *TEAR-OFF LABEL SHOULD BE APPLIED OVER GENSET NAMEPLATE VOLTAGE. REFER TO INSTALLATION MANUAL FOR DIRECTIONS.		
CAUTION: CIRCUIT BREAKER MAY NEED TO BE CHANGED.		
FOR GENERATOR SET MODEL: 22.5 MDKDT		
THIS SET HAS BEEN RECONFIGURED TO:		
Freq: 50HZ	AC Volts: 115/230V	Amps: 195.7/97.8
THIS SET HAS BEEN RECONFIGURED TO:		
Freq: 50HZ	AC Volts: 120/240V	Amps: 187.5/93.8
THIS SET HAS BEEN RECONFIGURED TO:		
Freq: 50HZ	AC Volts: 220V	Amps: 102.3
THIS SET HAS BEEN RECONFIGURED TO:		
Freq:	AC Volts:	Amps:
THIS SET HAS BEEN RECONFIGURED TO:		
Freq:	AC Volts:	Amps:
THIS SET HAS BEEN RECONFIGURED TO:		
Freq:	AC Volts:	Amps:
FOR GENERATOR SET MODEL: 27 MDKDU		
THIS SET HAS BEEN RECONFIGURED TO:		
Freq: 50HZ	AC Volts: 115/230V	Amps: 234.8/117.4
THIS SET HAS BEEN RECONFIGURED TO:		
Freq: 50HZ	AC Volts: 120/240V	Amps: 225/112.5
THIS SET HAS BEEN RECONFIGURED TO:		
Freq: 50HZ	AC Volts: 220V	Amps: 122.7
THIS SET HAS BEEN RECONFIGURED TO:		
Freq:	AC Volts:	Amps:
THIS SET HAS BEEN RECONFIGURED TO:		
Freq:	AC Volts:	Amps:
THIS SET HAS BEEN RECONFIGURED TO:		

FIGURE 45. TYPICAL RECONNECTION LABELS

7.2 Adjusting Voltage

Before adjusting voltage, make sure that proper fuel, exhaust, raw water, and battery connections have been made and that the engine has the proper levels of oil and coolant.

Disconnect all generator loads and connect accurate meters to measure AC voltage and frequency.

NOTICE

When reconnecting the generator for a different output voltage, make sure the line circuit breakers are suitable for the new output. Replace them if necessary with ones of appropriate rating.

⚠ WARNING

Hazardous Voltage

Touching uninsulated live parts inside the generator set and connected equipment can result in severe personal injury or death.

For your protection, stand on a dry wooden platform or rubber insulating mat, make sure your clothing and shoes are dry, remove jewelry from your hands, and use tools with insulated handles. Secure protective covers when completing installation.

7.3 Adjusting Voltage Using Digital Display

1. Start the generator set and let voltage and frequency stabilize for 5 to 10 seconds. Make sure all loads have been disconnected.
2. Rapidly press **START** 6 times during the first minute after startup to put the generator set control into voltage adjust mode. The green status lamp will blink rapidly and the display will indicate a status change from **Running** to **Volt Adj** (see Voltage Adjustment Screen figure below).
3. To adjust voltage up, press and quickly release **START**. Voltage will increase approximately 0.6 volts with each press and release.
4. To adjust voltage down, press and hold **START** for about 1 second. Voltage will decrease approximately 0.6 volts with each press and release.
5. When satisfied with the adjustment, wait about 20 seconds for the display to indicate a status change from **Volt Adj** to **Running** and then press **STOP** to stop the generator set and save the adjustment.
6. Restart the generator set and check voltage.
7. Recalibrate AC voltage on the digital display as instructed in the Operator Manual.

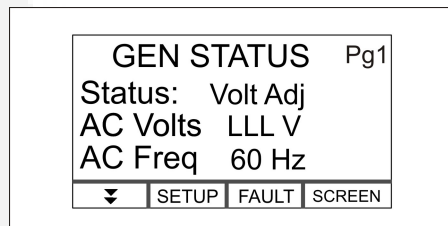

FIGURE 46. VOLTAGE ADJUSTMENT SCREEN

7.4 Adjusting Voltage Using Control Switch

1. Start the generator set and let voltage and frequency stabilize for 5 to 10 seconds. Make sure all loads have been disconnected.
2. Rapidly press **START** 6 times during the first minute after start up to put the generator set control into voltage adjust mode. The amber status lamp will begin blinking about once every second to indicate the change to voltage adjust mode. The green status lamp will remain on.
3. To adjust voltage up, press and quickly release **START**. Voltage will increase approximately 0.6 volts with each press and release.
4. To adjust voltage down, press and hold **START** for about 1 second. Voltage will decrease approximately 0.6 volts with each press and release.

-
5. When satisfied with the adjustment, wait about 20 seconds for the amber lamp to stop blinking and then press **STOP** to stop the generator set and save the adjustment.
 6. Restart the generator set and check voltage.



8 Troubleshooting

8.1 Overview

To troubleshoot the generator set, use the blinking control switch status lamp or the digital display fault code in conjunction with the following list of fault codes (listed in order by fault code number). Perform the step-by-step corrective actions suggested in this section.

NOTICE

Many generator set shutdowns can be avoided by performing periodic maintenance on schedule and by not running the generator set out of fuel. Note that when generator sets and propulsion engines draw from the same fuel tanks, the fuel pickup tubes are usually arranged so that the generator sets run out of fuel first. By marking the generator set empty points on the fuel gauges, it will be easier to tell when to stop the generator sets before running them out of fuel.

⚠ WARNING

Some generator set service procedures present hazards that can result in severe personal injury or death. Only trained and experienced service personnel with knowledge of fuels, electricity, and machinery hazards should perform generator set service. See the Safety Precautions chapter for more information on hazards.

⚠ WARNING

Accidental or remote starting can cause severe personal injury or death. Before removing a panel or access door, or before working on the generator set, use an insulated wrench to disconnect the negative (-) cable from the battery to prevent accidental starting.

8.2 Troubleshooting with Digital Display

If a fault shutdown occurs the ALARM status lamp on the Digital Display will blink and the LCD screen will display the Fault Number, a description of the fault and the hour the fault occurred in total generator set running time.

The fault will be displayed until it is cleared. Touch any button to clear the fault. The display will turn off in 5 minutes after the fault has been cleared.

See the Operator Manual for more information on displaying any of the last five faults.

8.3 Troubleshooting with Status Lamp

If a fault shutdown occurs, the amber status lamp on the control switch will repeatedly flash various sets of blinks.

- A set of one blink indicates shutdown due to high engine temperature.
- A set of two blinks indicates shutdown due to low oil pressure.

- A set of three blinks indicates a service fault.
 1. Press **Stop** once to cause the two-digit shutdown code to blink.

The two-digit code consists of two sets of blinks. The first set is 1 to 7 blinks, which represents the tens digit of the code number. There is a brief pause, then the second set of 1 to 9 blinks, which represents the units digit of the code number. This is followed by a longer pause and then repeats the process.

For example, Low Voltage Code No. 13 appears as: blink—*pause*—blink-blink-blink—*long pause*—repeat
 2. Pressing **Stop** again will stop the blinking.
- A set of four blinks indicates shutdown due to a failure to start within the time allowed for cranking.
- A set of five blinks indicates shutdown due to high levels of Carbon Monoxide (CO) in the vessel.
- A set of seven blinks indicates shutdown due to a loss of raw water flow for engine and exhaust cooling.

Blinking continues for five minutes and stops. To restore blinking press the control switch to **STOP (Prime)** until the lamp comes on (3 to 4 seconds). Then press **STOP (Prime)** three times to restore blinking.

NOTICE

The last fault logged will blink even though the condition that caused the shutdown may have been corrected.

8.4 Troubleshooting Generator Set Faults

⚠ WARNING

Some generator set service procedures present hazards that can result in severe personal injury or death. Only trained and experienced service personnel with knowledge of fuels, electricity, and machinery hazards should perform generator set service. See the Safety Precautions chapter for more information on hazards.

⚠ WARNING

Accidental or remote starting can cause severe personal injury or death. Before removing a panel or access door, or before working on the generator set, use an insulated wrench to disconnect the negative (-) cable from the battery to prevent accidental starting.

8.4.1 No Code - No Response at Digital Display or Control Switch

Logic:

Faulty switch, poor or missing connections, dead battery

Diagnosis and Repair:

Refer to Appendix drawings as appropriate.

1. Push the Emergency Stop to remove the emergency stop and/or DC Circuit Breaker **ON** if tripped.
2. Try the local digital display or control switch on the generator set if there is no response at a remote control switch, and vice versa. If at least one control switch or display works, but not the others, go to Step 7.
3. If no control switches work, service battery connections as necessary by cleaning and tightening, recharging or replacing the battery, or replacing damaged battery cables.
4. If there still is no response, disconnect the mate to connector J4 (P4, P33, or P43) in the control box. Check for battery voltage across pins J4-4 and J4-1 (B+, Display, Start/Stop, and ground). If there is voltage, go to Step 7. If there is no voltage, go to Step 5.
5. Disconnect connector P2 (gray) from the generator set controller and check for battery voltage across pin sockets P2-1 and P2-6. If there is voltage, replace the controller. If there is no voltage, go to Step 6.
6. Test the Emergency Stop Breaker (CB1) and the DC Circuit Breaker (CB2) and replace if necessary. If there still is no voltage, check for and repair faulty wiring and connectors between: P2-1 and CB2-LOAD; CB2-LINE and CB1-LOAD; CB1-LINE and B1-BAT; and P2-6 and GND-ENG.
7. Test for and replace a faulty Display or control switch and repair faulty wiring and connectors. See the Appendix for wiring connections.

8.4.2 No Code - Starter Engages and Disengages

Logic:

Low cranking voltage

Diagnosis and Repair:

1. De-energize the PTO clutch, if so equipped.
2. Service battery connections as necessary by cleaning and tightening, recharging or replacing the battery, or replacing damaged battery cables ([Section 3.3 on page 26](#)).
3. Service the starter ([Section 5.4 on page 70](#)). For additional information, see the appropriate engine Workshop Manual. See [Chapter 5](#).

8.4.3 No Code - Starting Batteries do not Maintain a Charge

Logic:

Marginal battery, battery connections or charging system

Diagnosis and Repair:

Refer to Appendix drawings as appropriate.

1. Service battery connections as necessary by cleaning and tightening, recharging or replacing the battery, or replacing damaged battery cables.
2. Check for and disconnect parasitic battery loads.
3. Service the battery starting alternator.

8.4.4 No Code - No AC Power When Generator Set is Running

Logic:

A Circuit Breaker is off, tripped or malfunctioning, or the generator is not connected properly.

Diagnosis and Repair:

Refer to Appendix drawings as appropriate.

1. Reset, turn on or repair the generator set circuit breaker if off or tripped.
2. Reset, turn on or repair any other circuit breaker in the AC power supply system if off or tripped.
3. If the generator set has a manual voltage regulator, push the manual voltage selector switch to auto.

8.4.5 Code No. 1 - High Engine Temperature

Logic: Engine coolant temperature exceeds design limit.

Diagnosis and Repair:

1. Check for and clean a blocked sea water strainer. If above the water line, fill the strainer with water to assist priming.
2. Check engine coolant level and add coolant as necessary.
3. Check for disconnected, kinked, or leaking hoses and reconnect, reroute, or replace.
4. Check for and readjust a loose pump belt.
5. Inspect the siphon break for proper operation.
6. Check for a worn raw water impeller and replace as necessary.
7. Clean the heat exchanger.
8. Check the bottom of the hull for any blockage at the through-hull fitting.
9. Drain and clean the coolant system to remove coolant passage fouling.
10. Replace the coolant thermostat, which might not be opening fully.
11. Check the ring terminal on coolant sender E2. Tighten if necessary.
12. Test coolant sender E2 and replace if necessary.
13. Disconnect connector P1 (black) from the generator set controller and check for electrical continuity between Pin 9 and the ring terminal on sender E2. If it is an isolated-ground sender, also check for electrical continuity between E2-2 and B- (ground). Repair wiring and connectors as necessary.
14. Replace the generator set controller.

8.4.6 Code No. 2 - Low Oil Pressure

Possible Cause:

Low oil pressure

Corrective Action:

1. Check the engine oil level and add or drain oil as necessary. Repair any oil leaks.

2. If loose, tighten the ring terminal on oil pressure sender E1.
3. Check electrical resistance through sender E1. Replace the sender if resistance is not between 227 and 257 ohms (0 psi) when the engine is stopped.
4. Disconnect connector P1 (black) from the generator set controller and check for electrical continuity between Pin 10 and the ring terminal on sender E1. If it is an isolated-ground sender, also check for electrical continuity between E1-2 and B- (ground). Repair wiring and connectors as necessary.
5. Replace the sender with a gauge, ground the sender wire (to keep the engine running) and start the engine. Shut down the engine immediately if there is no oil pressure. Service the engine lubricating system in accordance with the Engine Workshop Manual if oil pressure is less than 98 kPa (14 PSI).
6. Replace the generator set controller.

8.4.7 Code No. 3 - Service Check

Logic:

A fault with a 2-digit fault code number occurred.

Diagnosis and Repair:

Press the STOP switch once. The status lamp will blink the two-digit shutdown code which will be one of the codes in this section. (Does not apply to Digital Display.)

8.4.8 Code No. 4 - Overcrank

Possible Cause:

Cranking time exceeded 20 to 60 seconds, depending on engine temperature.

Diagnosis and Repair:

1. Disconnect the PTO clutch, if so equipped.
2. Check fuel level and refill as necessary. (Note: The generator set fuel pickups are probably higher than the propulsion engine fuel pickups.)
3. Open any closed fuel supply and return valves.
4. Prime the engine fuel system for at least 30 seconds.
5. Service as necessary by cleaning and tightening battery connections, recharging or replacing the battery, or replacing damaged battery cables.
6. Remove combustion air or exhaust system blockages.
7. Check all fuel fittings for fuel and air leaks, tighten as necessary and reprime.
8. Replace fuel filters and reprime.
9. Check for contaminated fuel by connecting to a source of known fuel quality.
10. Change engine oil. Use oil of the proper viscosity for the ambient temperature. High oil viscosity can slow cranking speed.
11. Conduct a fuel pump test and replace if necessary.
12. Inspect and service the glow plugs as follows:
 - a. If loose, tighten the glow plug terminals.

- b. Check for B+ at the glow plug terminals during cranking. If there is no B+, remove glow plug relay K3 from its socket in the control box, test for proper operation and replace if necessary. Also check for B+ at relay socket terminal 30, for continuity between terminal 87 and the glow plugs and for continuity between terminal 86 and B- (ground). Clean and tighten connections and replace wiring as necessary.
 - c. Check for B+ at relay socket terminal 85 while cranking. If there is no B+, disconnect connector P1 (black) from the generator set controller and check for a missing, bent or corroded pin (P1-1) and faulty wire and repair as necessary. If the wire and connections are good, replace the generator set controller.
 - d. Remove the glow plug bus bar and check for electrical continuity between each glow plug terminal and B- (ground). Replace any open glow plug.
13. Check for proper operation of the governor actuator and replace if necessary.
 14. Check compression and cylinder leak down and service a worn engine. See the Engine Workshop Manual.
 15. Service the fuel injectors. See the engine workshop manual.
 16. Check for proper operation of the internal governor mechanism. See the Engine Workshop Manual.

8.4.9 Code No. 5 - Warning Shutdown due to CO

Logic:

Dangerous levels of Carbon Monoxide in Vessel.

Diagnosis and Repair:

Get everyone out into fresh air immediately and seek medical attention.

8.4.10 Code No. 7 - Loss of Raw Water Flow

Logic:

Low raw water pressure in heat exchanger

Diagnosis and Repair:

1. Open the sea cock.
2. Check for and clean a blocked sea water strainer. If above the water line, fill the strainer with water to assist priming.
3. Check for disconnected, kinked, or leaking hoses and reconnect, reroute, or replace.
4. If loose, reconnect terminals S6+ and S6- to raw water flow switch S6.
5. Check for and readjust a loose pump belt.
6. Test raw water flow switch S6 and replace as necessary.
7. Check for a worn raw water impeller and replace as necessary.
8. Check the bottom of the hull for any blockage at the through-hull fitting.
9. Disconnect connector P1 (black) from generator set controller and check continuity between Pin 8 and terminal S6+ and between terminal S6- and B- (ground). Repair wiring and connectors as necessary.
10. Replace the generator set controller.

8.4.11 Code No. 12 - High AC Voltage

Logic:

After voltage regulation was enabled output voltage jumped to more than 125% of rated for 75 milliseconds or to more than 115% of rated for 3 seconds

Diagnosis and Repair:

1. Check for a tripped generator set circuit breaker, reset if necessary, and run with fewer loads. (A breaker tripping under load can cause generator set voltage to overshoot.)
2. Check all fuel fittings and filters for fuel and air leaks and tighten as necessary. (Air bubbles can disrupt generator set frequency/voltage.)
3. Check the brushes and slip rings, and rotor and stator windings. Service as necessary.
4. Prime the engine fuel system for at least 30 seconds.
5. Push the generator set line circuit breaker off, start the generator set, and measure output voltage. If output voltage is normal, the problem is in the circuits external to the generator set. If there is no voltage, test for grounded or shorted main, field or quadrature windings, and service as necessary.
6. Replace the generator set controller.

8.4.12 Code No. 13 - Low AC Voltage

Logic:

After voltage regulation was enabled output voltage fell to less than 90% of rated for 5 seconds.

Diagnosis and Repair:

1. Push the generator set line circuit breaker to off and disconnect the PTO, if so equipped. If the generator set now runs and voltage and frequency are normal, reduce the number of electrical and mechanical (PTO) loads. If there is no voltage, test for grounded or shorted main, field or quadrature windings, and service as necessary.
2. Check the fuel level and fill as necessary. (Note: The generator set fuel pickups are probably higher than the propulsion engine fuel pickups).
3. Remove combustion air or exhaust system blockages.
4. Prime the engine fuel system for at least 30 seconds.
5. Check all fuel fittings and filters for fuel and air leaks and tighten as necessary. (Air bubbles can disrupt generator set frequency/voltage.)
6. Replace fuel filters and reprime.
7. Conduct a fuel pump test and replace if necessary
8. Replace the generator set controller.
9. Check the brushes and slip rings, rotor and stator windings, and service as necessary.
10. Check for proper operation of the governor actuator and service or replace as necessary.
11. Re-adjust high idle speed.
12. Service the fuel injectors in accordance with the Engine Workshop Manual.
13. Check fuel injection timing in accordance with the Engine Workshop Manual..

14. Check for proper operation of the internal governor mechanism in accordance with the engine Workshop Manual.
15. Service a worn engine in accordance with the Engine Workshop Manual.

8.4.13 Code No. 14 - High AC Frequency

Logic:

After the starter was engaged frequency jumped to more than 70 Hz for 40 milliseconds or to more than 2% over nominal for 6 seconds.

Diagnosis and Repair:

1. Check for a tripped generator set circuit breaker, reset if necessary, and run with fewer loads. (A breaker tripping under load can cause generator set frequency to overshoot.)
2. Check all fuel fittings and filters for fuel and air leaks and tighten as necessary. (Air bubbles can disrupt frequency).
3. Check for proper operation of the governor actuator and replace if necessary.
4. Check for proper operation of the internal governor mechanism in accordance with the engine Workshop Manual.
5. Replace the generator set controller.

8.4.14 Code No. 15 - Low AC Frequency

Logic:

During normal operation Frequency fell to less than 90% of nominal for more than 8 seconds

Diagnosis and Repair:

1. Push the generator set line circuit breaker off and disconnect the PTO clutch, if so equipped. If the generator set now runs, reduce the number of electrical and mechanical (PTO) loads, especially those with high motor starting loads, such as air conditioners.
2. Check the fuel level and fill as necessary. (The generator set fuel pickups are probably higher than the propulsion engine fuel pickups causing the generator to run out of fuel before the propulsion engines).
3. Remove combustion air or exhaust system blockages.
4. Prime the engine fuel system for at least 30 seconds.
5. Check all fuel fittings for fuel and air leaks and tighten as necessary. (Air bubbles can disrupt frequency and voltage.)
6. Replace fuel filters and reprime.
7. Check for contaminated fuel by connecting to a source of known fuel quality.
8. Conduct a fuel pump test and replace if necessary.
9. Check for proper operation of the governor actuator and service or replace as necessary.
10. Re-adjust high idle speed.
11. Service the fuel injectors in accordance with the engine Workshop Manual.
12. Check fuel injection timing in accordance with the engine Workshop Manual.

13. Check for proper operation of the internal governor mechanism in accordance with the engine Workshop Manual.
14. Check compression and cylinder leak down. Service a worn engine in accordance with the engine Workshop Manual.
15. Replace the generator set controller

8.4.15 Code No. 22 - Governor Overload

Logic:

Maximum allowable time at full-duty cycle was exceeded

Diagnosis and Repair:

1. Reduce the number of appliances running, especially those with high motor starting loads such as air conditioners.
2. Check fuel level and refill as necessary. (Note: The generator set fuel pickups are probably higher than the propulsion engine fuel pickups, causing the generator to run out of fuel before the propulsion engine.)
3. Remove combustion air or exhaust system blockages.
4. Prime the engine fuel system for at least 30 seconds.
5. Check all fittings and fuel filters for fuel and air leaks, tighten as necessary, and reprime.
6. Replace fuel filters and reprime.
7. Check for contaminated fuel by connecting to a source of known fuel quality.
8. Conduct a fuel pump test and replace if necessary.
9. Check for proper operation of the governor actuator and replace if necessary.
10. Re-adjust high idle speed.
11. Service the fuel injectors in accordance with the engine Workshop Manual.
12. Check fuel injection timing in accordance with the engine Workshop Manual.
13. Check for proper operation of the internal governor mechanism in accordance with the engine Workshop Manual.
14. Check compression and cylinder leak down. Service a worn engine in accordance with the engine Workshop Manual.
15. Replace the generator set control.

8.4.16 Code No. 23 - Faulty Oil Pressure Sender

Logic:

Controller sensed grounded sender

Diagnosis and Repair:

1. If loose, tighten the ring terminal on oil pressure sender E1. (This fault will occur if a loose ring terminal touches grounded metal.)
2. Repair wiring and connectors as necessary to eliminate the ground path.

3. Check electrical resistance through sender E1. Replace the sender if resistance is not between 227 and 257 ohms (0 PSI) when the engine is stopped.
4. Replace the generator set controller.

8.4.17 Code No. 24 - Faulty Temperature Sender

Logic:

Controller sensed open sender

Diagnosis and Repair:

1. If loose, tighten the ring terminal on sender E2 . If it is an isolated-ground sender, also make sure flag terminal is connected to terminal 2 on sender.
2. Disconnect connector P1 (black) from generator set controller and check continuity between Pin 9 and ring terminal E2-1. If it is an isolated-ground sender, also check continuity between E2-2 and B- (ground). Repair wiring and connectors as necessary.
3. Test sender E2 and replace as necessary.
4. Replace the generator set controller.

8.4.18 Code No. 27 - Loss of AC Voltage Sense

Logic:

The generator set Controller lost VAC sensing during normal voltage regulation when the field was functioning normally and frequency was at least 40 Hz

Diagnosis and Repair:

1. Disconnect connector P3 (green) from the generator set controller and check continuity between Pin 11 (S1) and Pin 12 (S2). If open, check for missing, bent or corroded pins and faulty wiring and repair as necessary.
2. Test and service the generator as necessary.

8.4.19 Code No. 29 - High Battery Voltage

Logic:

During startup the generator set controller sensed that battery system voltage was greater than 19.2 volts if 12 VDC system, or 32.2 volts if 24 volt system.

Diagnosis and Repair:

1. Check battery bank connections and reconnect if necessary for 12 volts or 24 volts, depending on generator set model.
2. Select a lower battery booster charge rate (external charging system).

8.4.20 Code No. 32 - Starting Fault

Logic:

The generator set controller could not detect cranking speed [quadrature zero crossings] for 3 seconds.

Diagnosis and Repair:

1. Disconnect the PTO clutch, if so equipped.
2. Have the propulsion engines running while trying to start the generator set. Their charging alternators may be able to maintain a high enough battery terminal voltage to start the generator set.
3. Service the battery as necessary by cleaning and tightening connections, recharging or replacing the battery, or replacing damaged battery cables.
4. Change the engine oil to oil of the proper viscosity for the ambient temperature. (High oil viscosity can slow cranking speed).
5. Check for proper operation of starter relay K4 and replace if necessary.
6. Disconnect connector P3 (green) from generator set controller and measure resistance between Pin 10 and K4-86 and between K4-85 and CB2-2. If either lead is open, check for a missing, bent, or corroded pin or faulty wiring and repair as necessary.
7. Service the starter motor in accordance with the engine Workshop Manual.
8. Service the engine if the crankshaft is unusually hard to rotate manually, in accordance with the engine Workshop Manual.
9. Replace the generator set controller.

8.4.21 Code No. 35 - Control Card Failure - EE**Logic:**

During startup the generator set controller detected an EE memory error.

Diagnosis and Repair:

Replace the generator set controller.

8.4.22 Code No. 36 - Unknown Shutdown**Logic:**

The generator set controller declared this fault because engine speed fell below 1000 RPM for 0.5 seconds, though not by generator set or engine control action.

Diagnosis and Repair:

1. Check for mechanical damage and service as necessary.
2. Push the generator set line circuit breaker to off and disconnect the PTO clutch, if so equipped. If the generator set now runs, reduce the number of electrical and mechanical (PTO) loads.
3. Check fuel level and refill as necessary. (Note: The generator set fuel pickups are probably higher than the propulsion engine fuel pickups.)
4. Prime the engine fuel system for at least 30 seconds.
5. Remove combustion air or exhaust system blockages.
6. Check all fuel fittings for fuel and air leaks, tighten as necessary.
7. Replace fuel filters and reprime.
8. Conduct a fuel pump test and replace if necessary.

9. Disconnect connector P1 (black) from the generator set controller and measure resistance between Pin 5 and A12+ and between Pin 4 and A12-. If either lead is open, check for a missing, bent, or corroded pin, or faulty wiring. Repair as necessary.
10. Check for proper operation of the governor actuator and replace if necessary.
11. Service the brushes and slip rings as necessary and test the rotor and quadrature windings for opens and shorts. Replace a stator or rotor found to have faulty windings.
12. Check for a malfunctioning exciter or rotor, or open or grounded quadrature circuit. Service as necessary.
13. Service the fuel injectors in accordance with the engine Workshop Manual.
14. Check for proper operation of the internal governor mechanism in accordance with the engine Workshop Manual.
15. Check compression and cylinder leak down. Service a worn engine in accordance with the engine Workshop Manual.
16. Remove combustion air or exhaust system blockages.

8.4.23 Code No. 37 - Invalid Generator Set Configuration

Logic:

The generator set controller is not configured properly for the generator set.

Diagnosis and Repair:

1. Make sure the ends of the two leads marked CONFIG 1 and CONFIG 2 in the control box are not connected and that they are terminated with insulated connectors.
2. Reconfigure the generator set controller.
3. Replace the generator set controller.

8.4.24 Code No. 38 - Field Overload

Logic:

High field voltage induced by high rotor temperature or low power factor loads.

Diagnosis and Repair:

1. Remove blockages to generator air flow at the front inlet air grill.
2. Reduce the number of appliances running at the same time, especially those with high motor starting loads, such as air conditioners.
3. Have air conditioners and other appliances checked for proper operation. (A locked compressor rotor can cause very low power factor.)
4. Check for loose generator fan and repair or replace as necessary.
5. Test and service the generator as necessary.

8.4.25 Code No. 41 - Generator Rotor Fault

Logic:

F+ grounded.

Diagnosis and Repair:

1. Disconnect connector **P3** (green) from the generator set controller and check for continuity between Pin **P3-7** (F+) and **B-** (ground). Pin **P3-7** should not be grounded. Repair or replace wiring, brushes, slip rings, or rotor, as necessary.
2. Replace the generator set controller.

8.4.26 Code No. 43 - Control Card Failure - RAM**Logic:**

During startup the generator set Controller detected a RAM memory error

Diagnosis and Repair:

Replace the generator set controller.

8.4.27 Code No. 45 - Speed Sense Lost**Logic:**

After start disconnect the generator set controller lost speed sense [quadrature zero crossings] for 0.25 seconds.

Diagnosis and Repair:

1. Disconnect connector P3 (green) from generator set controller and check for open or shorted field (P3-7 to P3-8) and quadrature (P3-4 to P3-5) windings. Service generator as necessary.
2. Replace the generator set controller.

8.4.28 Code No. 57 - Overprime**Logic:**

A local or remote control switch was held in the prime position for more than 5 minutes.

Diagnosis and Repair:

1. Check for and remove any object that may be holding any control switch (local or remote) in the prime position.
2. Replace any control switch (S4) in the control system that does not open across terminals 1 and 2 when **Stop** is released.

8.4.29 Code No. 58 - High Exhaust Temperature**Logic:**

Exhaust temperature exceeded design limits due to lack of water delivered to the exhaust/water mixer.

Diagnosis and Repair:

1. Check for disconnected, kinked, or leaking water hoses and reconnect, reroute, or replace.
2. Check for and clean a blocked sea water strainer. If strainer is above the water line, fill with water to assist priming.
3. Inspect the siphon break (if provided) for proper operation.

4. If loose, reconnect terminals S5+ and S5- to high exhaust temperature switch S5.
5. Check for a worn raw water impeller and replace as necessary.
6. Clean the heat exchanger.
7. Disconnect connector P1 (black) from generator set controller and check continuity between Pin 11 and terminal S5+ and between terminal S5- and B- (ground). Repair wiring and connectors as necessary.
8. Test high exhaust temperature switch S5 and replace as necessary.
9. Replace the generator set controller.

8.4.30 Code No. 59 - Low Coolant Level

Logic:

The engine coolant level fell below the optional coolant level sensor

Diagnosis and Repair:

Add coolant as necessary and repair leaks.

8.4.31 Code No. 61 - External Shutdown

Logic:

The generator set was shut down by a fire suppression system or other external control.

Diagnosis and Repair:

Make all necessary repairs to the generator set and connected equipment. Reset the external control which shut down the generator set.

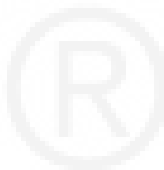

9 Specifications

9.1 13.5 MDKDP, 17.5 MDKDR, 19 MDKDV

TABLE 5. GENERATOR SET SPECIFICATIONS

DESCRIPTION	13.5 MDKDP	17.5 MDKDR	19 MDKDV
Alternator	Single-Bearing, 4-Pole Rotating Field, Brushless	Single-Bearing, 4-Pole Rotating Field, Brushless	Single-Bearing, 4-Pole Rotating Field, Brushless
Installation Drawing	A047E164	A047E164	A047E164
Engine	Kubota 4-Stroke Cycle, Indirect Injection, Water Cooled Diesel with Digital Electronic Governing	Kubota 4-Stroke Cycle, Indirect Injection, Water Cooled Diesel with Digital Electronic Governing	Kubota 4-Stroke Cycle, Indirect Injection, Water Cooled Diesel with Digital Electronic Governing
Model	V2003	V2403	V2403
Rated RPM			
60 Hz	N/A	N/A	N/A
50 Hz	1500	1500	1500
Number of Cylinders	4	4	4
Bore	83 mm (3.27 in)	87 mm (3.43 in)	87 mm (3.43 in)
Stroke	92.4 mm (3.64 in)	102.4 mm (4.03 in)	102.4 mm (4.03 in)
Displacement	1.999 L (121.99 in ³)	2.434 L (148.53 in ³)	2.434 L (148.53 in ³)
FUEL:			
BioDiesel Compatibility	N/A	N/A	N/A
Consumption - 60 Hz			
No Load	N/A	N/A	N/A
Half Load	N/A	N/A	N/A
Full Load	N/A	N/A	N/A
Consumption - 50 Hz			
No Load	1.1 L/hr (0.3 gal/hr)	1.1 L/hr (0.3 gal/hr)	1.1 L/hr (0.3 gal/hr)
Half Load	2.6 L/hr (0.7 gal/hr)	3.8 L/hr (1 gal/hr)	3.8 L/hr (1 gal/hr)
Full Load	4.9 L/hr (1.3 gal/hr)	6.4 L/hr (1.7 gal/hr)	6.4 L/hr (1.7 gal/hr)
Minimum Fuel Inlet Pressure	- 1.7 psi	- 1.7 psi	- 1.7 psi
Minimum Fuel Inlet Pressure with Auxiliary Pump	N/A	N/A	N/A
LUBRICATION:			
Engine Oil Capacity	5.6 L (6.0 qt)	5.6 L (6.0 qt)	5.6 L (6.0 qt)
Maximum Angularity Any Direction			

DESCRIPTION	13.5 MDKDP	17.5 MDKDR	19 MDKDV
Continuous	10°	10°	10°
Intermittent	22.5°	22.5°	22.5°
COOLING:			
Coolant Capacity	7.6 L (8.0 qt)	7.6 L (8.0 qt)	7.6 L (8.0 qt)
Coolant Flow Rate			
60 Hz	N/A	N/A	N/A
50 Hz	37.9 L/min (10 gal/min)	37.9 L/min (10 gal/min)	37.9 L/min (10 gal/min)
Raw Water Flow Rate			
60 Hz	N/A	N/A	N/A
50 Hz	26.5 L/min (7 gal/min)	26.5 L/min (7 gal/min)	26.5 L/min (7 gal/min)
Minimum Raw Water Inlet Pressure	- 1.7 psi	- 1.7 psi	- 1.7 psi
Maximum Pressure Drop across Keel Cooler Outlet and Inlet Connection	1 psi	1 psi	1 psi
Heat Rejection to Coolant			
60 Hz	N/A	N/A	N/A
50 Hz	379 Kcal/min (1500 BTU/min)	422 Kcal/min (1670 BTU/min)	422 Kcal/min (1670 BTU/min)
Thermostat Opening Temperature	71 °C (159.8 °F)	71 °C (159.8 °F)	71 °C (159.8 °F)
Thermostat Fully Open Temperature	85 °C (185 °F)	85 °C (185 °F)	85 °C (185 °F)
Recommended Pressure Cap	48 kPA (7 psi)	48 kPA (7 psi)	48 kPA (7 psi)
GENERATOR SET AIR FLOW:			
Combustion Air Flow	1.45 m ³ /min (52 ft ³ /min)	1.72 m ³ /min (60 ft ³ /min)	1.72 m ³ /min (60 ft ³ /min)
Heat Rejection to Ambient			
60 Hz	N/A	N/A	N/A
50 Hz	72 Kcal/min (285 Btu/min)	88 Kcal/min (350 Btu/min)	88 Kcal/min (350 Btu/min)
EXHAUST:			
Maximum Exhaust Back Pressure	3 in Hg	3 in Hg	3 in Hg
Dry Exhaust Gas Flow	4.5 m ³ /min (160 ft ³ /min)	5.1 m ³ /min (180 ft ³ /min)	5.1 m ³ /min (180 ft ³ /min)
Dry Exhaust Temperature	-	-	-
BATTERIES:			
Nominal Battery Voltage	12/24 VDC	12/24 VDC	12/24 VDC
Minimum CCA Rating - SAE @ 0 °C (32 °F) 12 VDC	500 Amps	625 Amps	625 Amps
12 Volt Net Battery Charging Output			
Negative Ground (60 Hz)	N/A	N/A	N/A

DESCRIPTION	13.5 MDKDP	17.5 MDKDR	19 MDKDV
Isolated Ground (60 Hz)	N/A	N/A	N/A
Negative Ground (50 Hz)	25 Amps	25 Amps	25 Amps
Isolated Ground (50 Hz)	35 Amps	35 Amps	35 Amps
24 Volt Net Battery Charging Output	-	-	-
Negative Ground (60 Hz)	N/A	N/A	N/A
Isolated Ground (60 Hz)	N/A	N/A	N/A
Negative Ground (50 Hz)	13 Amps	13 Amps	13 Amps
Isolated Ground (50 Hz)	24 Amps	24 Amps	24 Amps
Starter Rolling Current			
12V	N/A	N/A	N/A
24V	N/A	N/A	N/A
Maximum Starting Current Resistance			
12V	N/A	N/A	N/A
24V	N/A	N/A	N/A
SIZE, WEIGHT, NOISE:			
Weight without Sound Shield:			
Dry Weight	377 kg (830 lb)	375 kg (870 lb)	375 kg (870 lb)
Weight with Sound Shield:			
Dry Weight	404 kg (890 lb)	422 kg (930 lb)	422 kg (930 lb)
Sound Level with Sound Shield @ 1 meter	64 dB(A)	64 dB(A)	64 dB(A)
Sound Pressure Level with Sound Shield @ 1 meter per ISO-3744	N/A	N/A	N/A

9.2 17 MDKDP, 21.5 MDKDR

TABLE 6. GENERATOR SET SPECIFICATIONS

DESCRIPTION	17 MDKDP	21.5 MDKDR
Alternator	Single-Bearing, 4-Pole Rotating Field, Brushless	Single-Bearing, 4-Pole Rotating Field, Brushless
Installation Drawing	A047E164	A047E164
Engine	Kubota 4-Stroke Cycle, Indirect Injection, Water Cooled Diesel with Digital Electronic Governing	Kubota 4-Stroke Cycle, Indirect Injection, Water Cooled Diesel with Digital Electronic Governing
Model	V2403	V2403
Rated RPM		

DESCRIPTION	17 MDKDP	21.5 MDKDR
60 Hz	1800	1800
50 Hz	N/A	N/A
Number of Cylinders	4	4
Bore	87 mm (3.43 in)	87 mm (3.43 in)
Stroke	102.4 mm (4.03 in)	102.4 mm (4.03 in)
Displacement	2.434 L (148.53 in ³)	2.434 cm ³ (148.53 in ³)
FUEL:		
BioDiesel Compatibility	N/A	N/A
Consumption - 60 Hz		
No Load	1.8 L/hr (0.5 gal/hr)	1.9 L/hr (0.5 gal/hr)
Half Load	3.6 L/hr (1.0 gal/hr)	4.1 L/hr (1.1 gal/hr)
Full Load	6.1 L/hr (1.6 gal/hr)	8.2 L/hr (2.2 gal/hr)
Consumption - 50 Hz		
No Load	N/A	N/A
Half Load	N/A	N/A
Full Load	N/A	N/A
Minimum Fuel Inlet Pressure	- 1.7 psi	- 1.7 psi
Minimum Fuel Inlet Pressure with Auxiliary Pump	N/A	N/A
LUBRICATION:		
Engine Oil Capacity	5.6 L (6.0 qt)	5.6 L (6.0 qt)
Maximum Angularity Any Direction		
Continuous	10°	10°
Intermittent	22.5°	22.5°
COOLING:		
Coolant Capacity	7.6 L (8.0 qt)	7.6 L (8.0 qt)
Coolant Flow Rate		
60 Hz	53 L/min (14 gal/min)	53 L/min (14 gal/min)
50 Hz	N/A	N/A
Raw Water Flow Rate		
60 Hz	59.1 L/min (15.6 gal/min)	34.1 L/min (9 gal/min)
50 Hz	N/A	N/A
Minimum Raw Water Inlet Pressure	- 1.7 psi	- 1.7 psi
Maximum Pressure Drop across Keel Cooler Outlet and Inlet Connection	1 psi	1 psi
Heat Rejection to Coolant		
60 Hz	402 Kcal/min (1590 BTU/min)	570 Kcal/min (2260 BTU/min)
50 Hz	N/A	N/A
Thermostat Opening Temperature	71 °C (159.8 °F)	71 °C (159.8 °F)

DESCRIPTION	17 MDKDP	21.5 MDKDR
Thermostat Fully Open Temperature	85 °C (185 °F)	85 °C (185 °F)
Recommended Pressure Cap	48 kPA (7 psi)	48 kPA (7 psi)
GENERATOR SET AIR FLOW:		
Combustion Air Flow	1.72 m ³ /min (60 ft ³ /min)	1.72 m ³ /min (60 ft ³ /min)
Heat Rejection to Ambient		
60 Hz	88 Kcal/min (350 Btu/min)	120 Kcal/min (478 Btu/min)
50 Hz	N/A	N/A
EXHAUST:		
Maximum Exhaust Back Pressure	3 in Hg	3 in Hg
Dry Exhaust Gas Flow	5.1 m ³ /min (180 ft ³ /min)	5.1 m ³ /min (180 ft ³ /min)
Dry Exhaust Temperature	555 °C (1031 °F)	555 °C (1031 °F)
BATTERIES:		
Nominal Battery Voltage	12/24 VDC	12/24 VDC
Minimum CCA Rating - SAE @ 0 °C (32 °F) 12 VDC	625 Amps	625 Amps
12 Volt Net Battery Charging Output		
Negative Ground (60 Hz)	29 Amps	29 Amps
Isolated Ground (60 Hz)	38 Amps	38 Amps
Negative Ground (50 Hz)	N/A	N/A
Isolated Ground (50 Hz)	N/A	N/A
24 Volt Net Battery Charging Output		
Negative Ground (60 Hz)	14 Amps	14 Amps
Isolated Ground (60 Hz)	28 Amps	28 Amps
Negative Ground (50 Hz)	N/A	N/A
Isolated Ground (50 Hz)	N/A	N/A
Starter Rolling Current		
12V	N/A	N/A
24V	N/A	N/A
Maximum Starting Current Resistance		
12V	N/A	N/A
24V	N/A	N/A
SIZE, WEIGHT, NOISE:		
Weight without Sound Shield:		
Dry Weight	381 kg (840 lb)	375 kg (870 lb)
Weight with Sound Shield:		
Dry Weight	408 kg (899 lb)	422 kg (930 lb)

DESCRIPTION	17 MDKDP	21.5 MDKDR
Sound Level with Sound Shield @ 1 meter	N/A	N/A
Sound Pressure Level @ meter per ISO 3744 with soundshield	70 dB(A)	70 dB(A)

9.3 22.5 MDKDT, 27 MDKDU, 29 MDKDS

TABLE 7. GENERATOR SET SPECIFICATIONS

DESCRIPTION	22.5 MDKDT	27 MDKDU	29 MDKDS
Alternator	Single-Bearing, 4-Pole Rotating Field, Brushless	Single-Bearing, 4-Pole Rotating Field, Brushless	Single-Bearing, 4-Pole Rotating Field, Brushless
Installation Drawing	A047E158	A047E158	A047E158
Engine	Kubota 4-Stroke Cycle, Indirect Injection, Water Cooled Diesel with Digital Electronic Governing	Kubota 4-Stroke Cycle, Indirect Injection, Water Cooled Diesel with Digital Electronic Governing	Kubota 4-Stroke Cycle, Indirect Injection, Water Cooled Diesel with Digital Electronic Governing
Model	V3300	V3300	V3300
Rated RPM			
60 Hz	N/A	N/A	1800
50 Hz	1500	1500	N/A
Number of Cylinders	4	4	4
Bore	98 mm (3.86 in)	98 mm (3.86 in)	98 mm (3.86 in)
Stroke	110 mm (4.33 in)	110 mm (4.33 in)	110 mm (4.33 in)
Displacement	3.318 L (202.48 in ³)	3.318 cm ³ (202.48 in ³)	3.318 L (202.48 in ³)
FUEL:			
BioDiesel Compatibility	N/A	N/A	N/A
Consumption - 60 Hz			
No Load	N/A	N/A	2.4 L/hr (0.6 gal/hr)
Half Load	N/A	N/A	5.6 L/hr (1.5 gal/hr)
Full Load	N/A	N/A	10.7 L/hr (2.8 gal/hr)
Consumption - 50 Hz			
No Load	1.9 L/hr (0.5 gal/hr)	1.9 L/hr (0.5 gal/hr)	N/A
Half Load	4.5 L/hr (1.2 gal/hr)	4.5 L/hr (1.2 gal/hr)	N/A
Full Load	9.1 L/hr (2.4 gal/hr)	9.1 L/hr (2.4 gal/hr)	N/A
Minimum Fuel Inlet Pressure	- 1.7 psi	- 1.7 psi	- 1.7 psi
Minimum Fuel Inlet Pressure with Auxiliary Pump	N/A	N/A	N/A
LUBRICATION:			
Engine Oil Capacity	10.4 L (11 qt)	10.4 L (11 qt)	10.4 L (11 qt)

DESCRIPTION	22.5 MDKDT	27 MDKDU	29 MDKDS
Maximum Angularity any Direction			
Continuous	10°	10°	10°
Intermittent	22.5°	22.5°	22.5°
COOLING:			
Coolant Capacity	14 L (14.5 qt)	14 L (14.5 qt)	14 L (14.5 qt)
Coolant Flow Rate			
60 Hz	N/A	N/A	53 L/min (14 gal/min)
50 Hz	43.5 L/min (11.5 gal/min)	43.5 L/min (11.5 gal/min)	N/A
Raw Water Flow Rate			
60 Hz	N/A	N/A	59.1 L/min (15.6 gal/min)
50 Hz	49.2 L/min (13 gal/min)	49.2 L/min (13 gal/min)	N/A
Minimum Raw Water Inlet Pressure	- 1.7 psi	- 1.7 psi	- 1.7 psi
Maximum Pressure Drop across Keel Cooler Outlet and Inlet Connection	1 psi	1 psi	1 psi
Heat Rejection to Coolant			
60 Hz	N/A	N/A	625 Kcal/min (2480 BTU/min)
50 Hz	470 Kcal/min (1870 BTU/min)	555 Kcal/min (2200 BTU/min)	N/A
Thermostat Opening Temperature	76.5 °C (170 °F)	76.5 °C (170 °F)	76.5 °C (170 °F)
Thermostat Fully Open Temperature	90 °C (194 °F)	90 °C (194 °F)	90 °C (194 °F)
Recommended Pressure Cap	48 kPA (7 psi)	48 kPA (7 psi)	48 kPA (7 psi)
GENERATOR SET AIR FLOW:			
Combustion Air Flow	2.6 m ³ /min (91.7 ft ³ /min)	2.6 m ³ /min (91.7 ft ³ /min)	2.6 m ³ /min (91.7 ft ³ /min)
Heat Rejection to Ambient			
60 Hz	N/A	N/A	149 Kcal/min (590 Btu/min)
50 Hz	111 Kcal/min (441 Btu/min)	130 Kcal/min (515 Btu/min)	N/A
EXHAUST:			
Maximum Exhaust Back Pressure	3 in Hg	3 in Hg	3 in Hg
Dry Exhaust Gas Flow	6.8 m ³ /min (240 ft ³ /min)	6.8 m ³ /min (240 ft ³ /min)	6.8 m ³ /min (240 ft ³ /min)
Dry Exhaust Temperature	475 °C (887 °F)	475 °C (887 °F)	526 °C (958 °F)
BATTERIES:			
Nominal Battery Voltage	12/24 VDC	12/24 VDC	12/24 VDC
Minimum CCA Rating - SAE @ 0 °C (32 °F) 12 VDC	1400 Amps	1400 Amps	1400 Amps

DESCRIPTION	22.5 MDKDT	27 MDKDU	29 MDKDS
12 Volt Net Battery Charging Output			
Negative Ground (60 Hz)	N/A	N/A	28 Amps
Isolated Ground (60 Hz)	N/A	N/A	37 Amps
Negative Ground (50 Hz)	20 Amps	20 Amps	N/A
Isolated Ground (50 Hz)	33 Amps	33 Amps	N/A
24 Volt Net Battery Charging Output			
Negative Ground (60 Hz)	N/A	N/A	21 Amps
Isolated Ground (60 Hz)	N/A	N/A	26 Amps
Negative Ground (50 Hz)	23 Amps	23 Amps	N/A
Isolated Ground (50 Hz)	23 Amps	23 Amps	N/A
Starter Rolling Current			
12V	N/A	N/A	N/A
24V	N/A	N/A	N/A
Maximum Starting Current Resistance			
12V	N/A	N/A	N/A
24V	N/A	N/A	N/A
SIZE, WEIGHT, NOISE:			
Weight without Sound Shield:			
Dry Weight	565 kg (1245 lb)	590 kg (1300 lb)	590 kg (1300 lb)
Weight with Sound Shield:			
Dry Weight	601 kg (1325 lb)	626 kg (1380 lb)	626 kg (1380 lb)
Sound Level with Sound Shield @ 1 meter	67 dB(A)	65 dB(A)	N/A
Sound Pressure Level at 1 meter with Sound Shield per ISO-3744	N/A	N/A	70 dB(A)



This page is intentionally blank.



Appendix A. Wiring Diagrams

Table of Contents

Figure 47. A049H027 Sheet 1	117
Figure 48. A049H027 Sheet 2	118
Figure 49. A049H027 Sheet 3	119

The drawings included in this section are representative. For current complete information, refer to the drawing package that was shipped with the unit.



A.1 Wiring Drawing

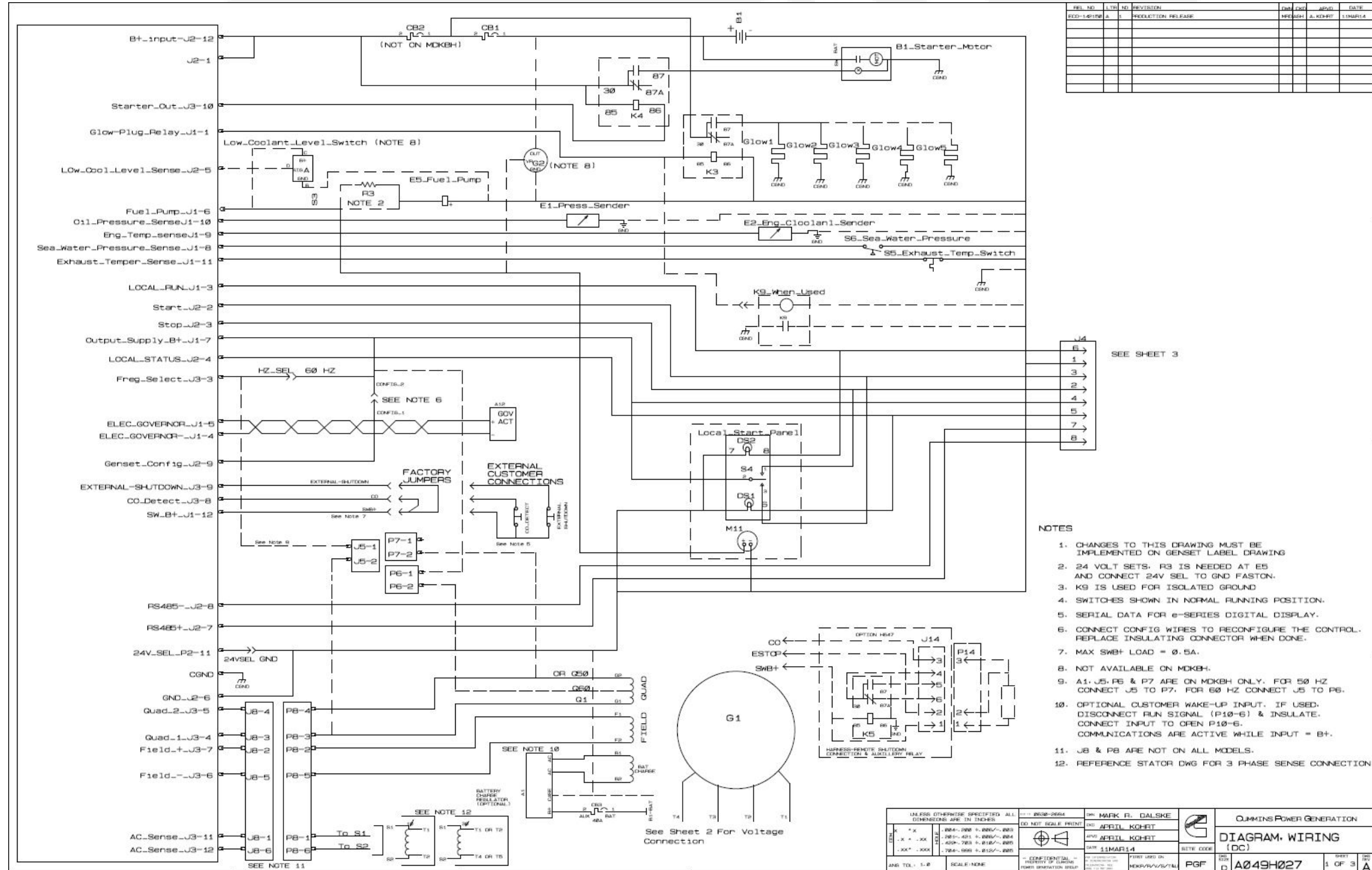

FIGURE 47. A049H027 SHEET 1

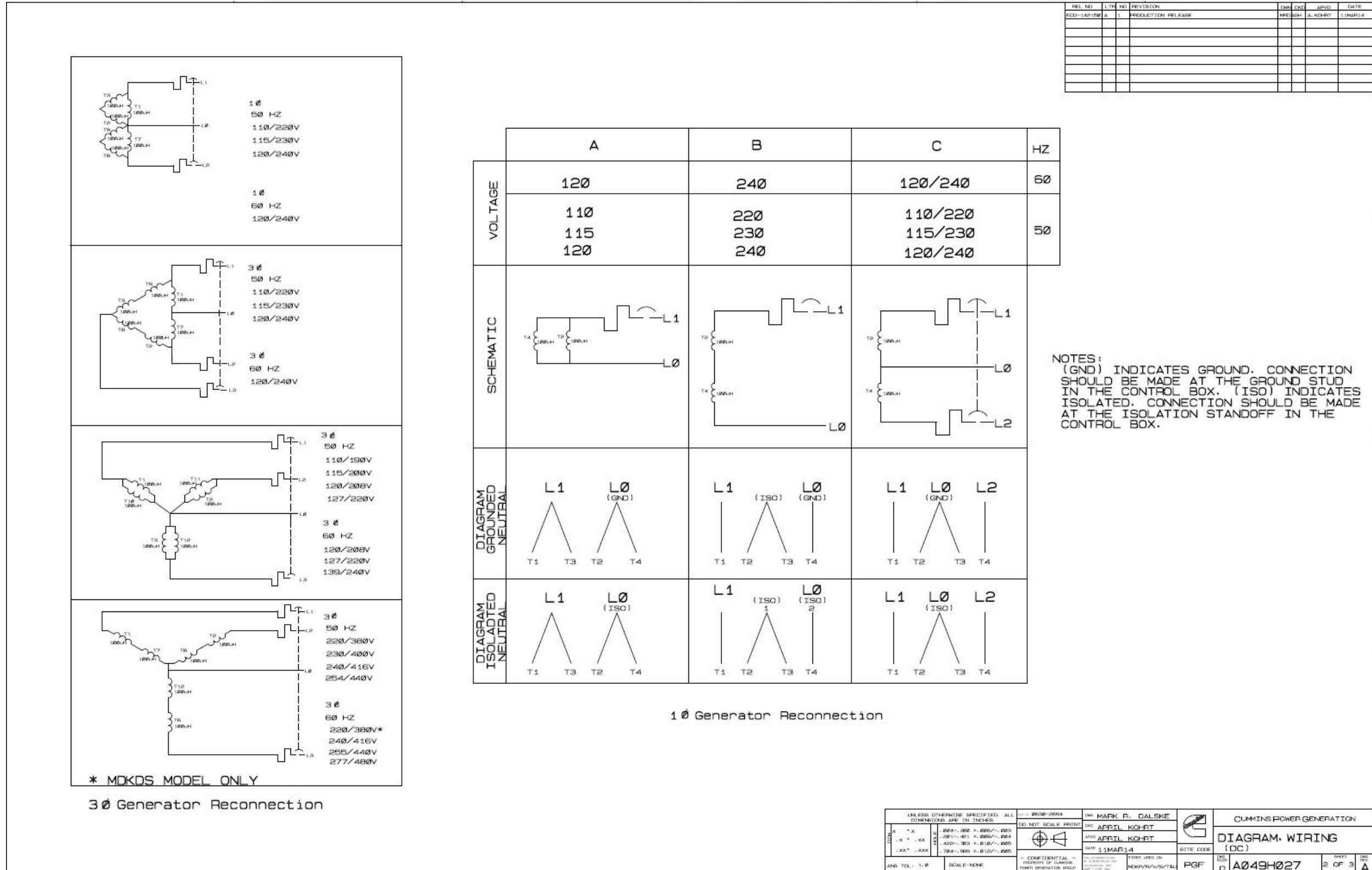

FIGURE 48. A049H027 SHEET 2

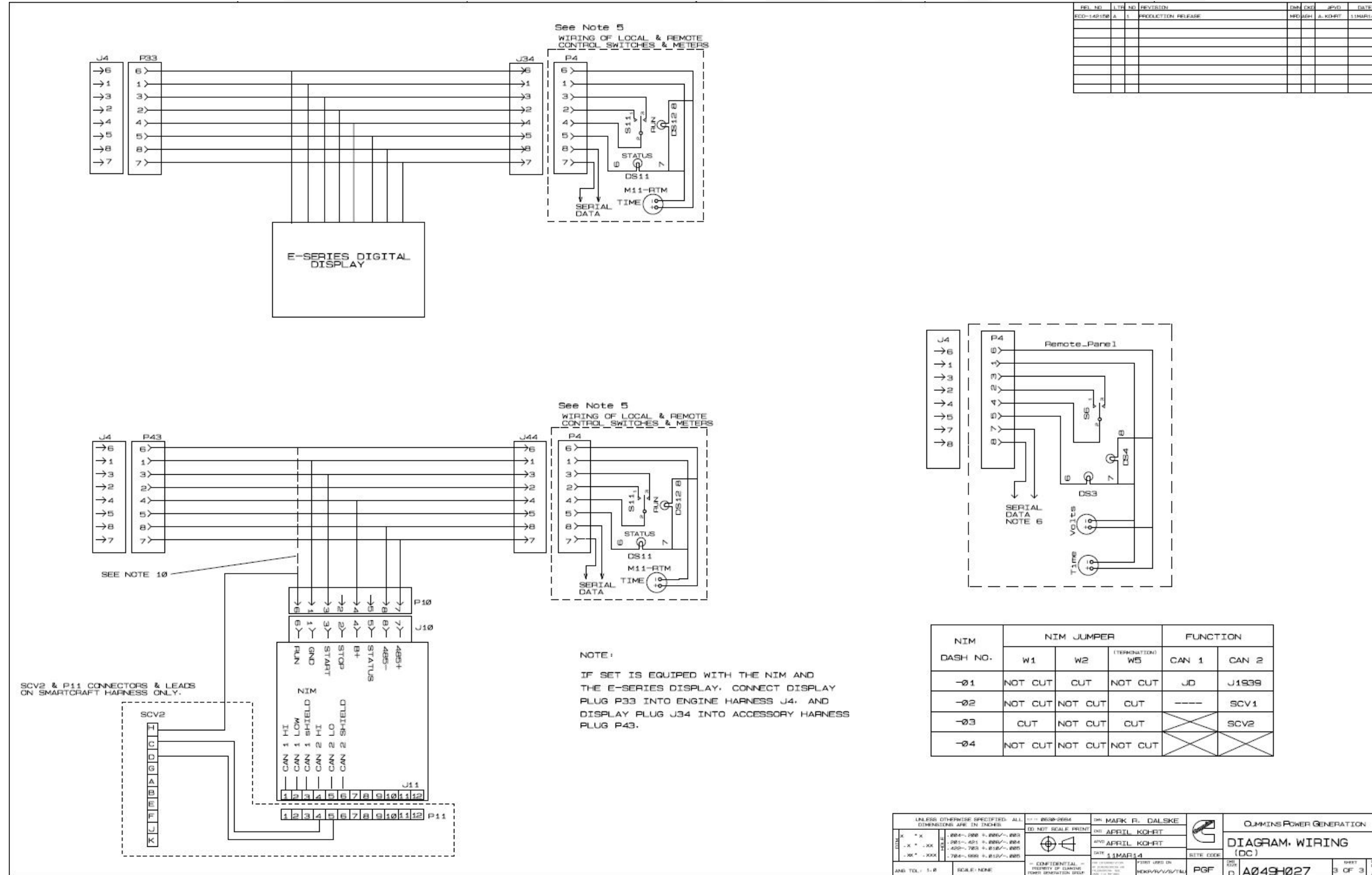
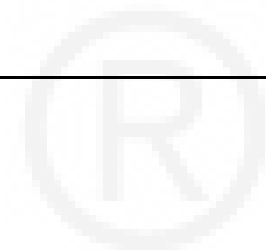

FIGURE 49. A049H027 SHEET 3

This page is intentionally blank.



Appendix B. Outline Drawings

Table of Contents

Figure 50. MDKDP, MDKDR, MDKDV Outline Drawing (Sheet 1)	123
Figure 51. MDKDP, MDKDR, MDKDV Outline Drawing (Sheet 2)	124
Figure 52. MDKDP, MDKDR, MDKDV Outline Drawing (Sheet 3)	125
Figure 53. MDKDS, MDKDT, MDKDU Outline Drawing (Sheet 1)	126
Figure 54. MDKDS, MDKDT, MDKDU Outline Drawing (Sheet 2)	127
Figure 55. MDKDS, MDKDT, MDKDU Outline Drawing (sheet 3)	128

The drawings included in this section are representative. For current complete information, refer to the drawing package that was shipped with the unit.



B.1 MDKDP, MDKDR, MDKDV Outline Drawing

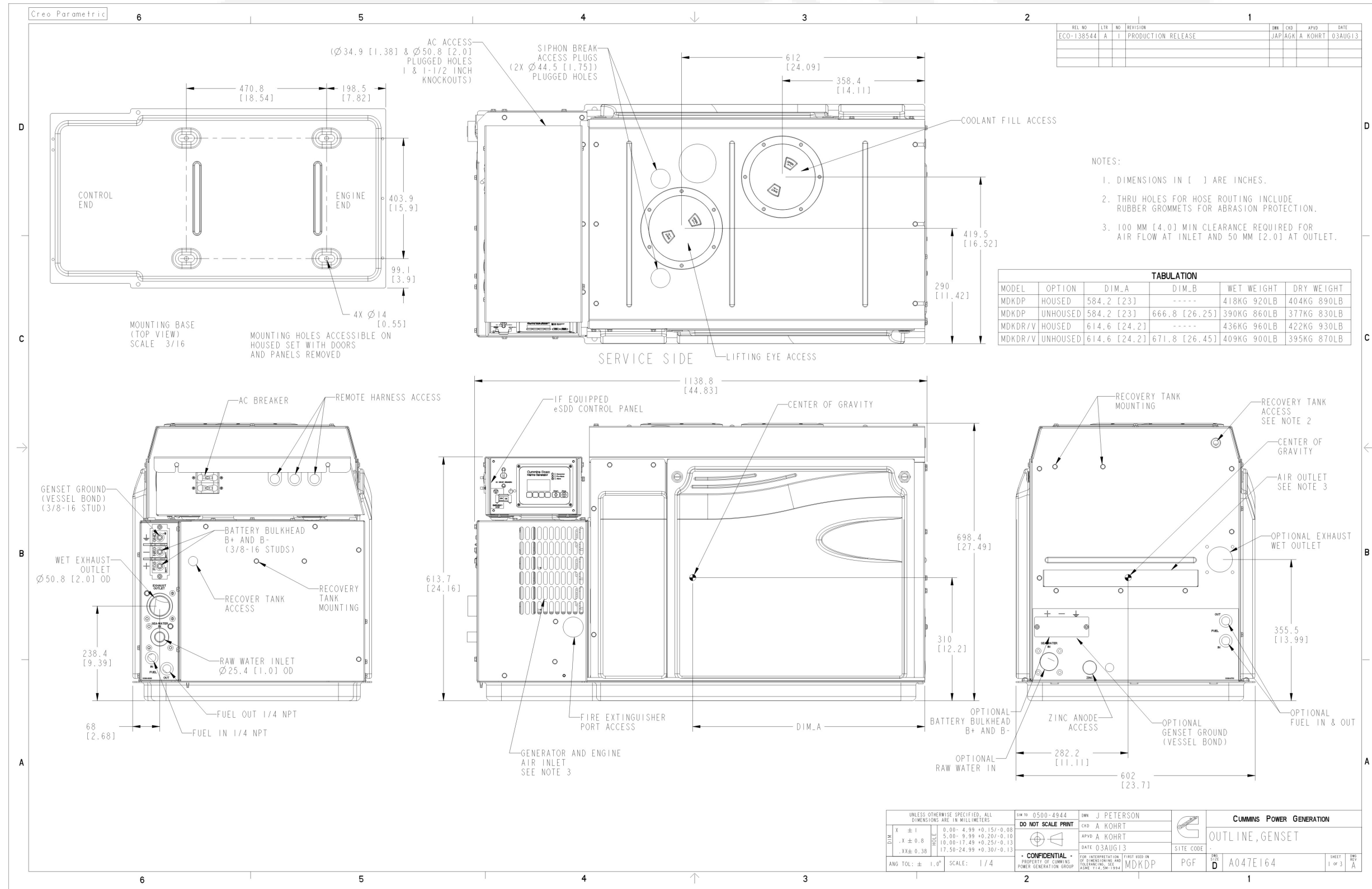

FIGURE 50. MDKDP, MDKDR, MDKDV OUTLINE DRAWING (SHEET 1)

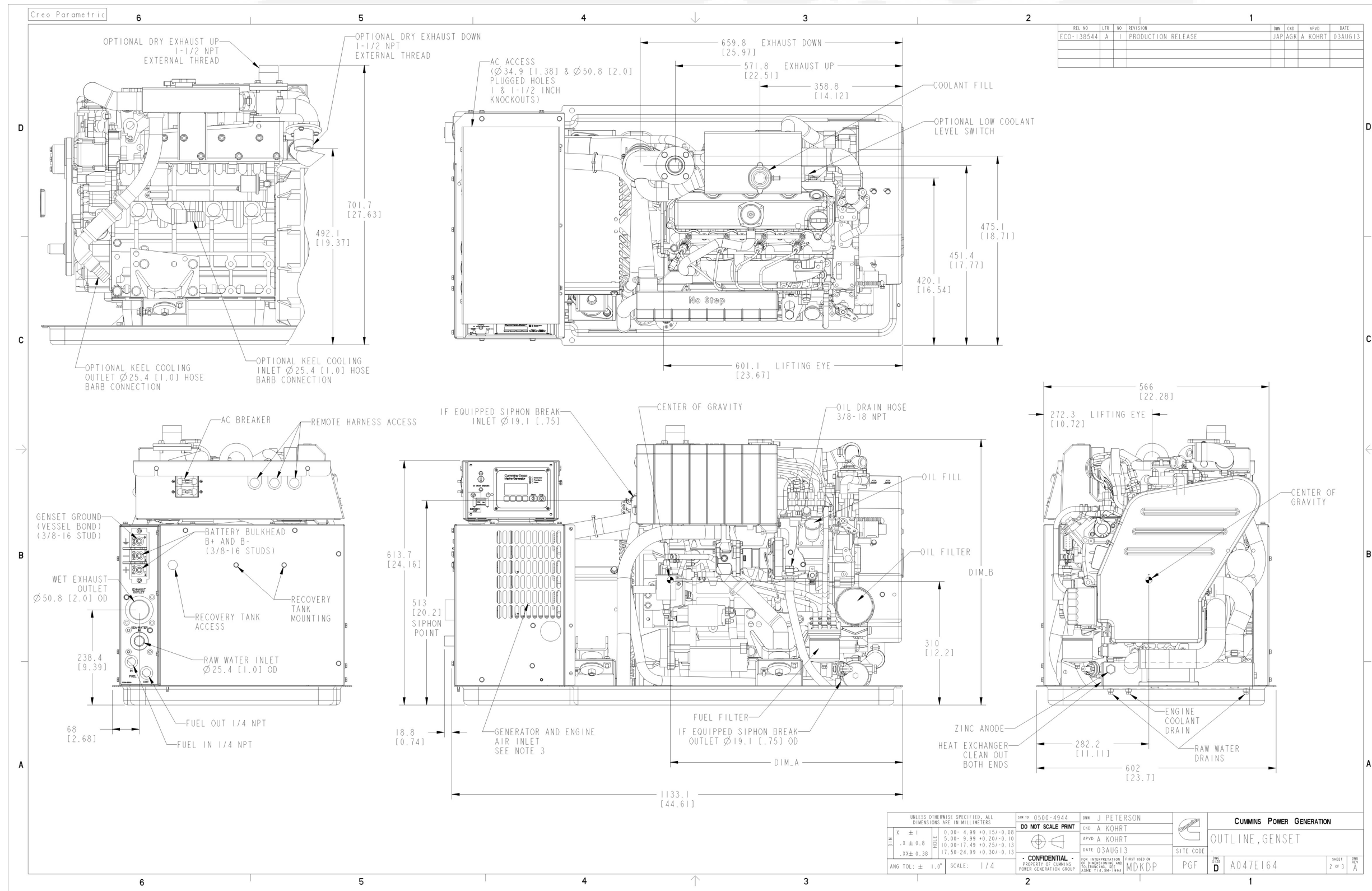
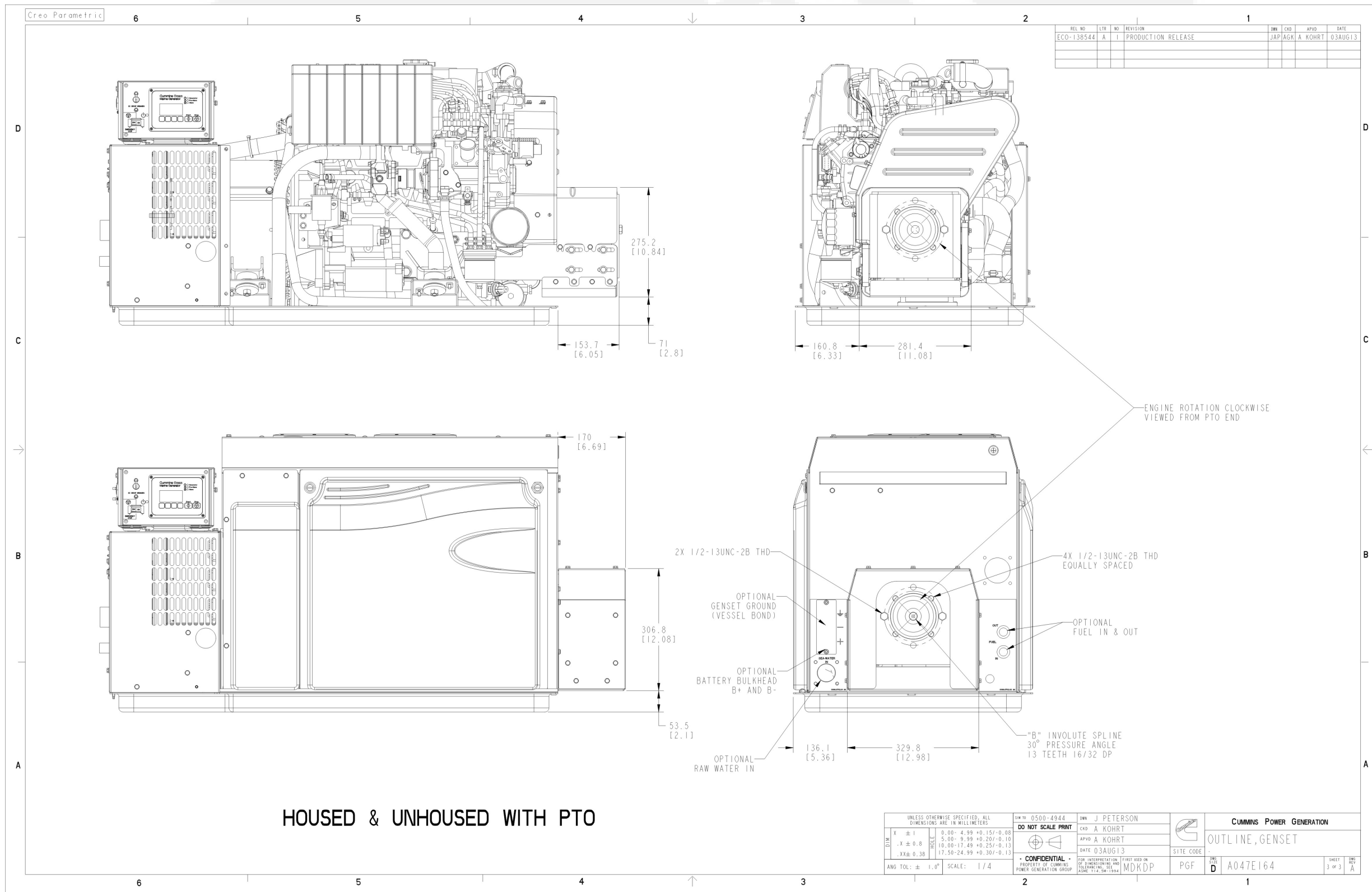

FIGURE 51. MDKDP, MDKDR, MDKDV OUTLINE DRAWING (SHEET 2)

FIGURE 52. MDKDP, MDKDR, MDKDV OUTLINE DRAWING (SHEET 3)



B.2 MDKDS, MDKDT, MDKDU Outline Drawing

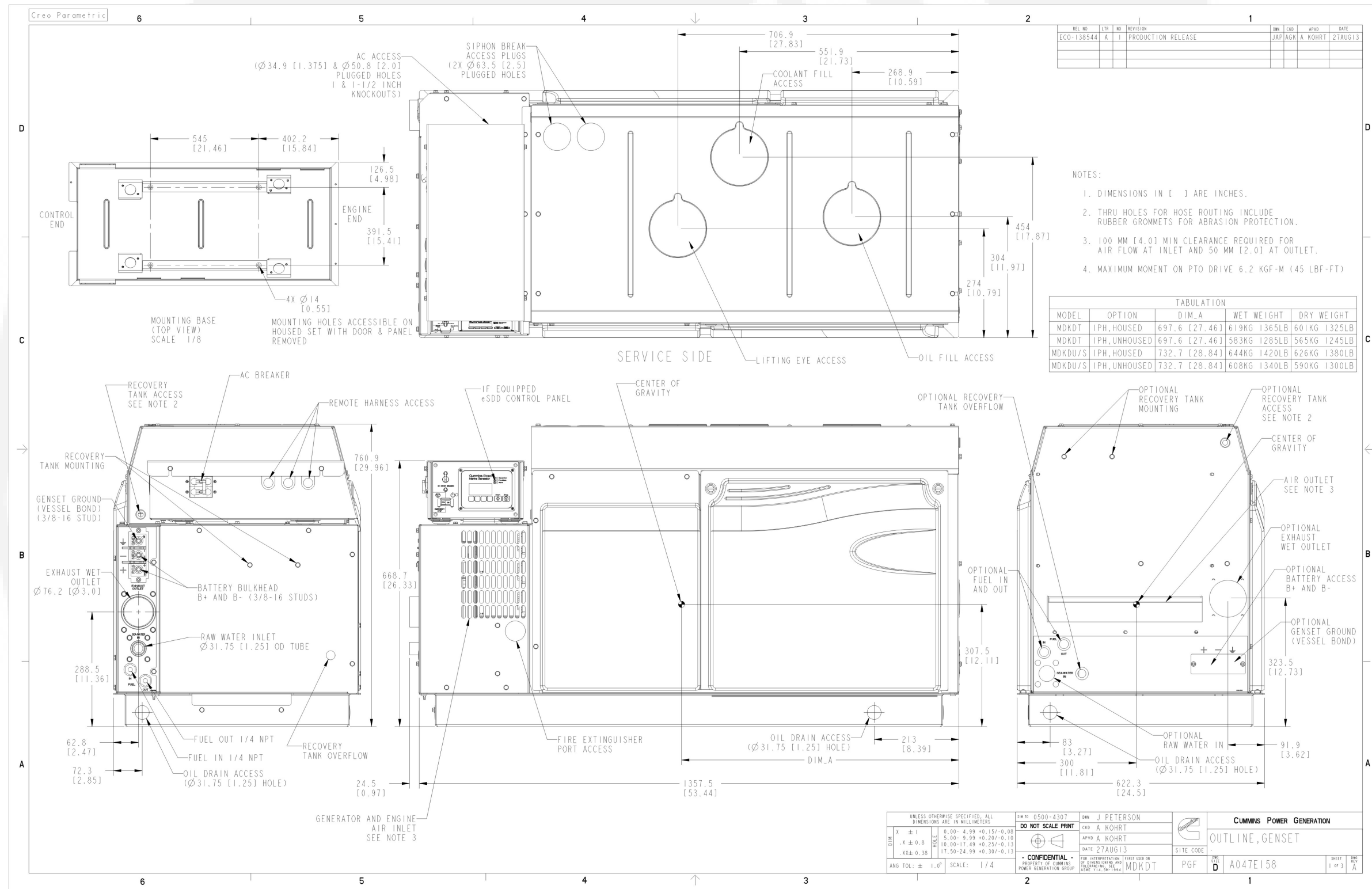
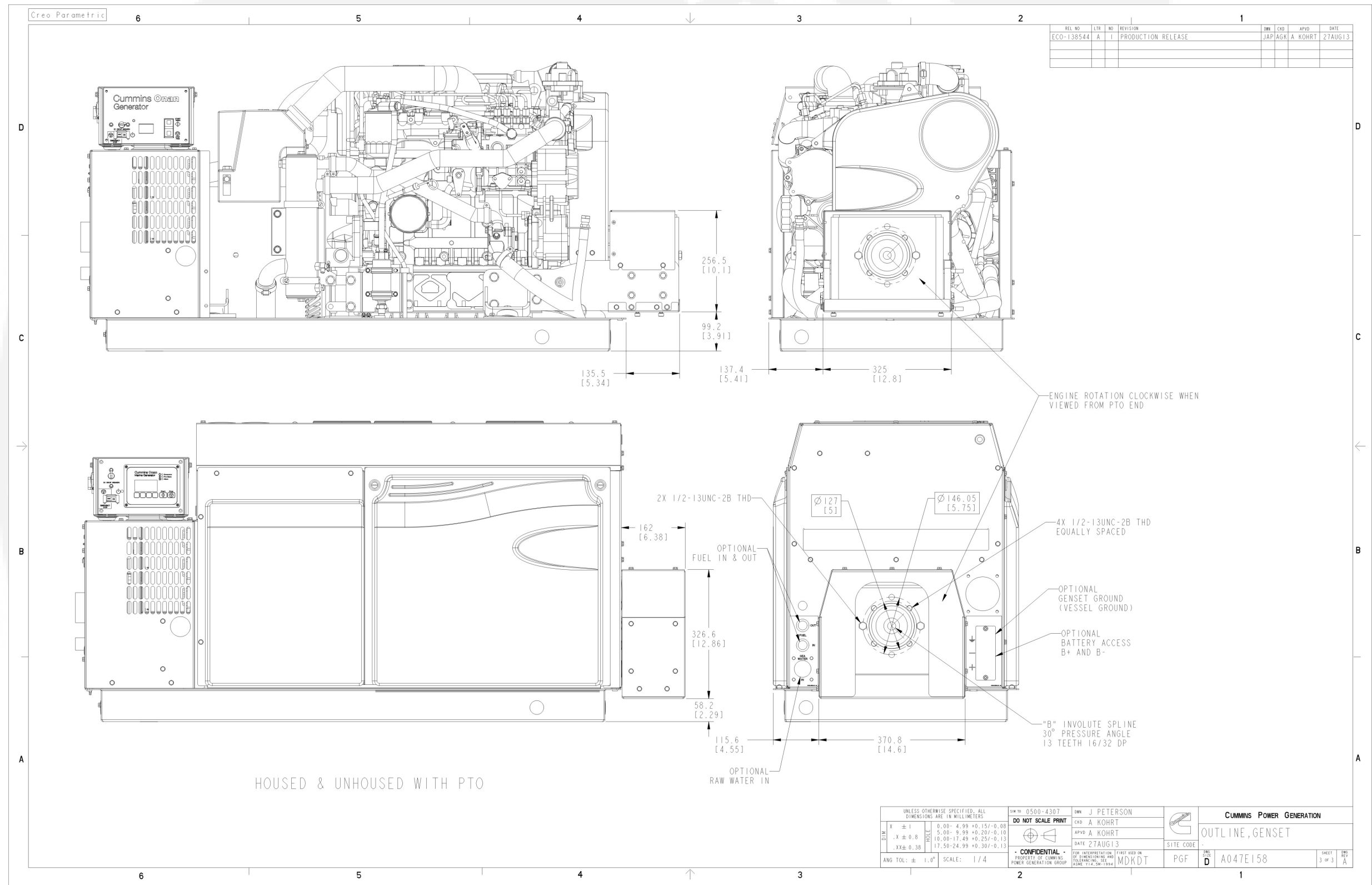

FIGURE 55. MDKDS, MDKDT, MDKDU OUTLINE DRAWING (SHEET 3)



Appendix C. Wiring Harnesses

Table of Contents

Figure 56. 338-4790 Wiring Harness (MDKDS, MDKDT, MDKDU)	131
Figure 57. 338-5174 Wiring Harness (MDKDP, MDKDR, MDKDV)	132

The drawings included in this section are representative. For current complete information, refer to the drawing package that was shipped with the unit.



C.1 MDKD Wiring Harnesses

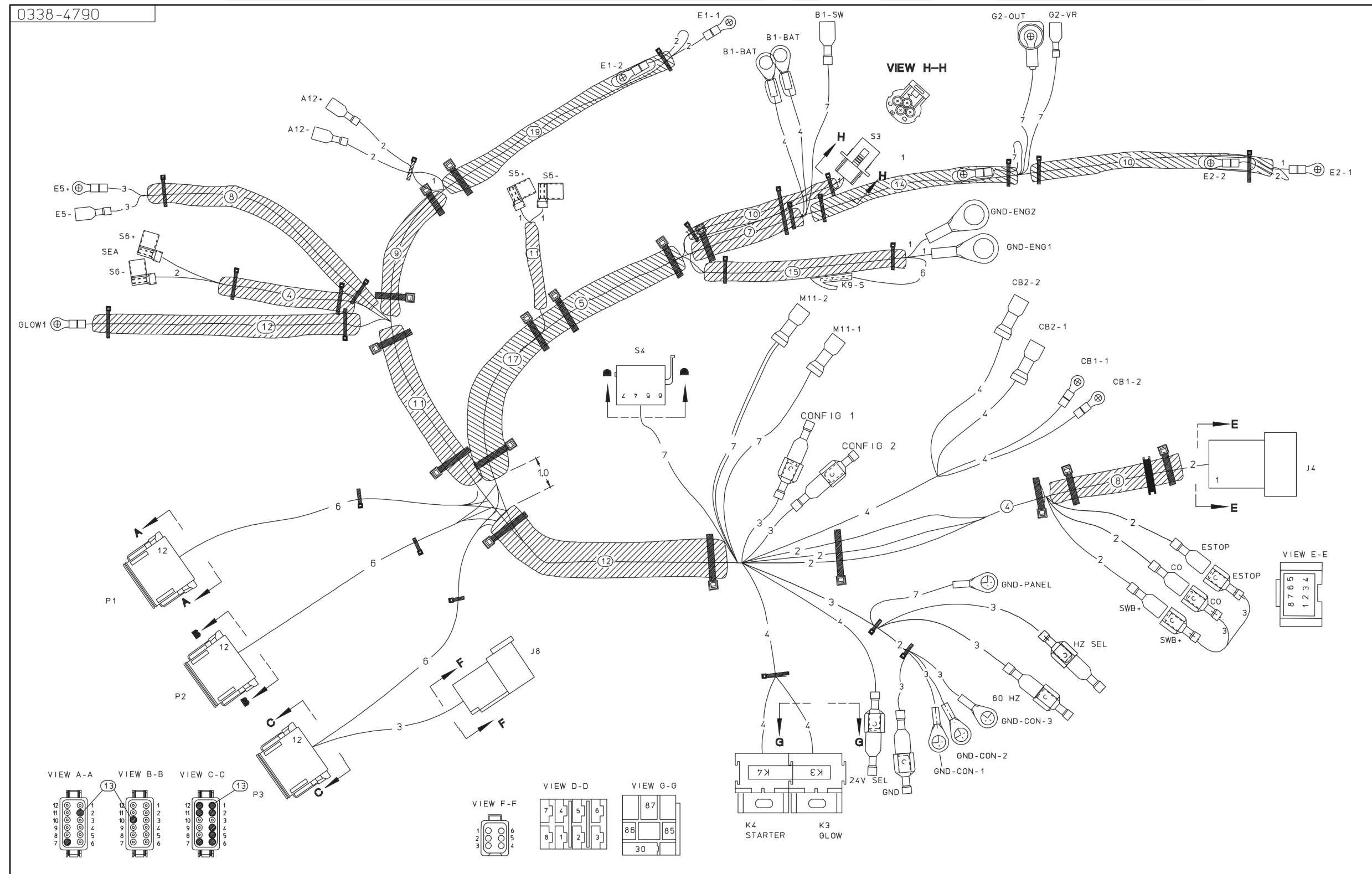

FIGURE 56. 338-4790 WIRING HARNESS (MDKDS, MDKDT, MDKDU)

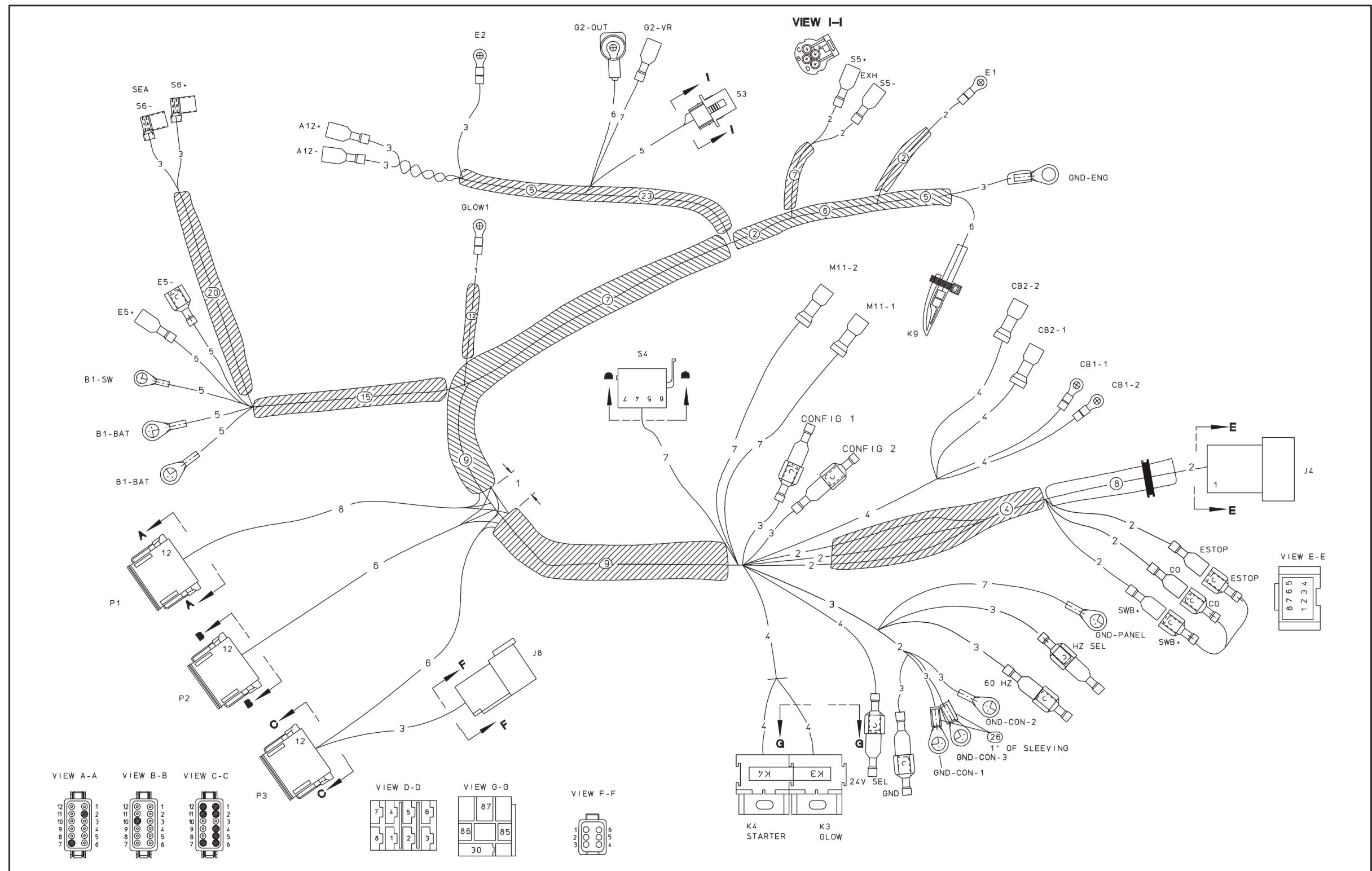

FIGURE 57. 338-5174 WIRING HARNESS (MDKDP, MDKDR, MDKDV)

www.cumminsonan.com

Copyright © 2015 Cummins Power Generation, Inc. All rights reserved.
Cummins, Onan, the "C" logo, and "Performance you rely on." are trademarks of Cummins Inc. Other company, product, or service names may be trademarks or service marks of others. Specifications are subject to change without notice.

